

Multi Protocol Analyzer **LE-8200**

New portable protocol analyzer "LE-8200" with color display runs by battery power.

Standard Board Supports

RS-232C

RS-422

RS-485

Expansion Boards Support

TTL

I²C

SPI

IrDA

CAN

LIN

FlexRay

USB

LAN

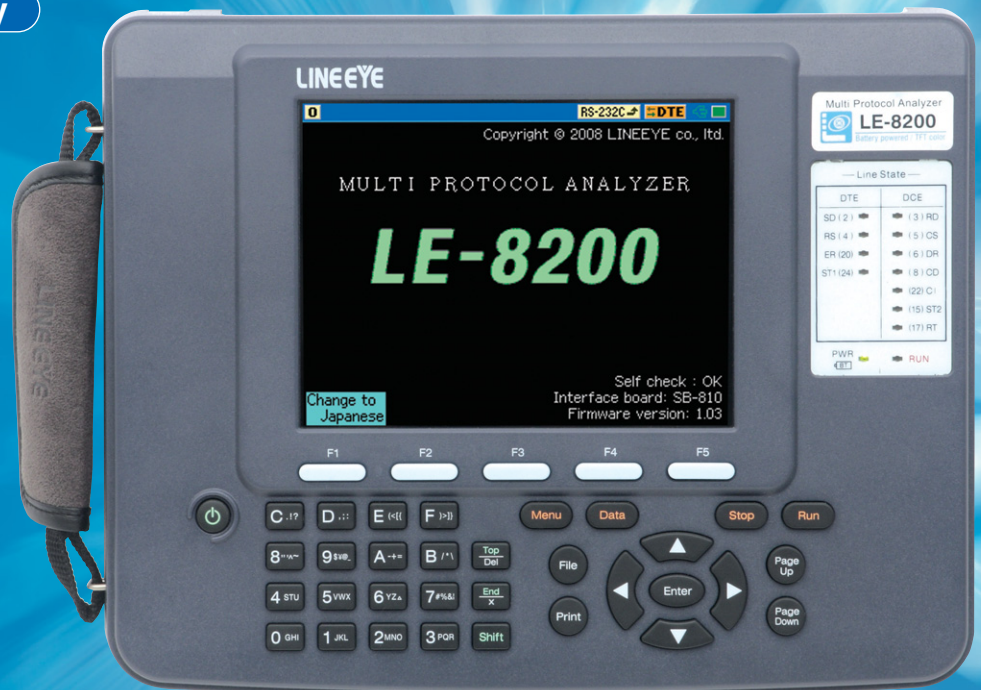

Wide Color LCD

Mega Speed Measurement

Giga Byte Long Hour Record



Battery-powered Portable Multi Protocol Analyzer

Communications Analyzer **LE-8200**



A product incorporating features for the protection of the global environment, such as the elimination of toxic substances, and a power-saving design.

The LE-8200 is the top-level model of battery-powered portable communications analyzers. The LE-8200 has an enlarged display in response to an increasing demand without degrading the excellent portability of the LE Series. The LE-8200 is ideal for development tests of communications systems, industrial equipment, a variety of in-vehicle networks, and after-sale services for products along with trouble analysis.

A battery-powered model in B5 size, weighing 1.1 kg, and operating continuously for 4 hours.

RS-422/RS-485 (RS-530) measurement port

Used for X.21, RS-449, and V.35 communications over dedicated cable^{(*)1} with no extra attachments required.

DC input connector

Used to connect the AC adapter (provided) that covers a global range of power supply voltage.

External signal terminal

Used for external signal voltage measurement input and external trigger I/O signals.

RS-232C (V.24) measurement port

Used to connect the dedicated cable^{(*)1} with DSUB 9 pins for measurement.

Exchangeable measurement board



5.7-inch TFT color display

Provided with a power-saving white LED backlight.

Hand strap



Power supply ON/OFF switch

Auto power-off is possible.

Function keys

Used to make displayed code changes or screen mode changes.

Special data items are expressed in individual signs.

(Example of display signs)

| | |
|--|------------------------------|
| | Start flag |
| | End flag |
| | Short frame |
| | Block check OK |
| | Block check NG |
| | Parity error |
| | Framing error |
| | PE and FE simultaneous error |
| | Break |

Idle time (frame interval time)

Time stamp (frame arrival time)

Menu key

Used to begin operations.

Measurement start key

Automatic repetitive measurement is possible at specified times.

Line State LED

Continuously displays the state of communications line with a 2-color LED.

| | |
|--|------------------------------|
| | Red: ON space state |
| | Green: OFF mark state |
| | OFF: Not in use or not wired |



^{(*)1}: An optional dedicated cable is required.
^{(*)2}: The optional PC Link software is required.
^{(*)3}: The CF card slot guarantees the operation of only LINEEYE's optional CF card.

Powerfully backing up the measurement of communications networks of ubiquitous society.

5.7-inch Large-sized Color TFT LCD

The large-sized LCD is an easy-to-understand color display showing a flow of communications protocol and data transmitted or received, thus greatly improving the efficiency of measurement data analysis. Furthermore, the display of an English or Japanese guide accurately supports high-level measurement over communications.

[Example of Japanese display]

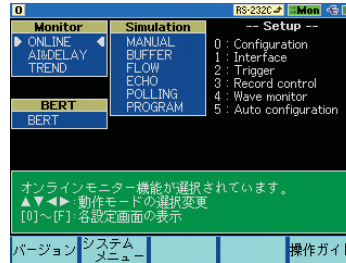

[Example of English display]

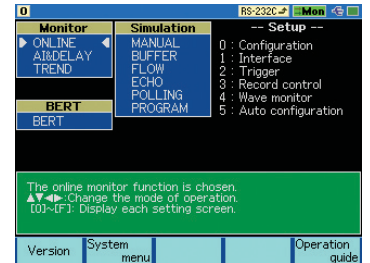

Supports TTL, I²C, SPI, IrDA, CAN, LIN, FlexRay, USB, and LAN

Supports various types of communications protocols widely used over RS-232C/422/485. Also supports new communications standards by exchanging the measurement board.

See pages 8 and 12 for details.

Measurement Functions Developed in Response to Customers' Demands

Incorporates improved measurement functions, such as the comparison display of two divided areas, precise time stamp recording in 1- μ s units, and improved triggering with the simultaneous detection of eight conditions.

See pages 4 and 5 for details.

Long Recording Time of Communications Data

Incorporates a 100-MB capture memory that is ideal for the analysis of high-speed, large-volume communications. The use of the CF card enables the continuous recording of communications data for as long as several days.

See page 4 for details.

Supports Logic Analyzer Analysis and Analog Waveform Analysis

Realizes precise timing analysis and waveform observation easily with no general-purpose measuring instruments used.

See page 5 for details.

Measurement at Low to Mega Speeds

Using high-precision DPLL technology for open baud rate support, transmission and reception speeds can be separately set to 4 effective digits for measurement tests.

See page 4 for details.

Measurement Linked with PC

The PC link function(*), which realizes PC-linked measurement, enables high-speed USB connections, thus performing the remote monitoring of measuring objects at high speed. *: The optional PC Link software is required.

See page 13 for details.

AUX connector

Used for printing out and firmware updating.

USB2.0 connector

PC linking is possible at high-speed transmission.^(*)

CF card slot

The CF card with a maximum capacity of 32 gigabytes is supported.^(*)

Incorporating remote monitor, simulation, and BERT functions to improve the efficiency of the development testing and trouble analysis of RS-232C/RS-422/RS-485 communications.

Multi Protocol Analyzer **LE-8200**



The monitor function exactly records and visualizes communications data.

The line monitor function allows the recording of communications data and provides an easy-to-understand large-sized display without affecting the communications lines. This function makes it possible to grasp the conditions of transmission and reception, thus greatly shortening the required time of troubleshooting. As a standard feature, the LE-8200 supports a variety of communications standards, such as binary synchronous communications (BSC) for character-synchronous transmission, and high-level data link control (HDLC) for bit-synchronous transmission as well as asynchronous communications that are widely used for PC peripheral and microcontroller applications. By adding an optional expansion kit, the LE-8200 will support many more communications standards.

[Example of connection for online monitoring]

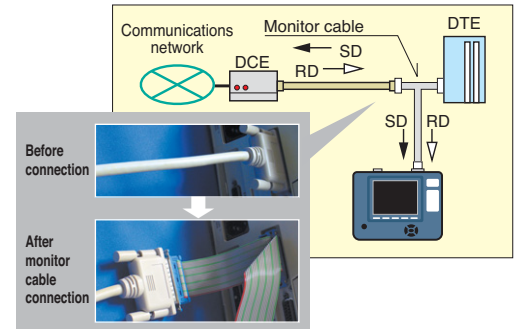

[Example of display with line state]

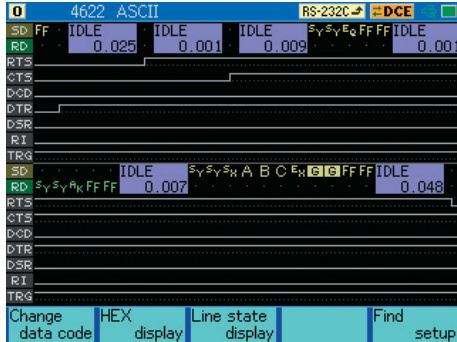

[Example of X.25 protocol translation]

| Time | Ad | Type | NS | PF | NR | FC | Data |
|----------|----|------|----|----|----|-------------------------|------|
| 07:23:02 | 01 | SABM | 1 | | | | |
| 07:23:02 | 03 | UA | 1 | | | | |
| 07:23:04 | 01 | INFO | 0 | 0 | 0 | 30 37 35 2b 36 39 58 2b | |
| 07:23:04 | 03 | REJ | 0 | 0 | 0 | | |
| 07:23:05 | 01 | INFO | 0 | 0 | 0 | 30 37 35 2b 36 39 58 2b | |
| 07:23:05 | 03 | INFO | 0 | 0 | 1 | 50 52 4f 54 4f 43 4f 4c | |
| 07:23:05 | 01 | INFO | 1 | 0 | 0 | 4c 49 4e 45 45 59 45 | |
| 07:23:05 | 03 | REJ | 0 | 1 | 1 | | |
| 07:23:06 | 01 | INFO | 1 | 0 | 0 | 4c 49 4e 45 45 59 45 | |
| 07:23:06 | 03 | INFO | 2 | 0 | 1 | 41 4e 41 4c 59 59 45 52 | |
| 07:23:06 | 03 | INFO | 2 | 0 | 2 | 4c 45 2b 38 32 30 30 | |
| 07:23:07 | 01 | RR | 0 | 3 | | | |
| 07:23:07 | 01 | DISC | 1 | | | | |
| 07:23:07 | 03 | UA | 1 | | | 33 64 | |

[Example of PPP translation]

| Time | Protocol | Code | ID | FC | Data |
|----------|----------|---------|-----|----|-------------------|
| 58:25:07 | VJCTCPIP | RES-REP | 62 | | 7E 65 6c 6c 70 61 |
| 58:25:22 | VJCTCPIP | 4c | 1 | | 34 6c 00 05 84 00 |
| 58:25:36 | VJCTCPIP | 2f | 144 | | E9 00 02 a2 61 73 |
| 58:25:52 | VJCTCPIP | 44 | 1 | | 2E 88 00 05 84 |
| 58:25:61 | VJCTCPIP | RES-REP | 249 | | 0E 69 73 74 22 3E |
| 58:25:72 | VJCTCPIP | 64 | 1 | | 29 04 00 05 84 02 |
| 58:25:87 | VJCTCPIP | 2f | 72 | | 8E 00 02 28 48 2f |
| 58:26:02 | VJCTCPIP | 44 | 1 | | 23 50 00 05 84 |
| 58:26:12 | VJCTCPIP | RES-REP | 199 | | 1c 74 22 3e 3c 69 |
| 58:26:28 | IP | 45 | 0 | | 00 38 07 39 00 00 |
| 58:26:32 | VJCTCPIP | 64 | 1 | | 19 9c 00 05 84 02 |
| 58:26:38 | VJCTCPIP | 2f | 153 | | F2 00 01 e4 83 68 |
| 58:26:52 | VJCTCPIP | 44 | 1 | | 17 E8 00 05 84 |
| 58:26:64 | VJCTCPIP | RES-REP | 123 | | 95 69 66 74 79 20 |

Display of Two Divided Areas for Ease of Comparison

The display of two divided areas is convenient for the comparison of normal and abnormal communications log records. It is possible to scroll the two divided areas on the upper half and lower half of the screen individually or simultaneously, which allows the comparison of the two communications records efficiently.

[Example of two divided areas]

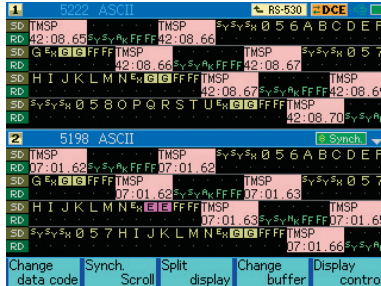

Freely Set with Four Effective Digits for Transmission and Reception

Using high-precision DPLL technology for open baud rate support, transmission and reception speeds can be separately set with 4 effective digits to a baud rate range between 50 bps and 4 Mbps. The required conditions of transmission or reception data, such as the bit configuration, bit transfer sequence, polarity, and modulation format can be freely selected to meet many test situations.

[Example of communications protocol settings]

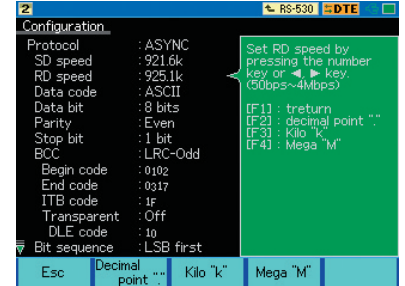

High-precision Time Stamp Recorded at 1-μs Intervals

The time stamp shows the transmission or reception time of the head data of each communications frame. In addition to the conventional real-time time stamp, the LE-8200 incorporates a high-precision time stamp that records the elapsed time of transmission or reception at minimal 1-μs intervals from the start of measurement. This function has widened the range of applications from the narrowing down of data on a specified time-and-date basis and delicate timing basis. Moreover, the LE-8200 displays idle time, thus making it possible to check the response time and timeout of transmission or reception at a glance. In addition, it is possible to judge each frame in ASYNC communications by specifying a non-communications period of 1 to 100 ms or end data.

[Example of time stamp]

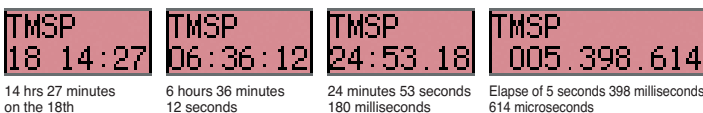

[Example of idle time]



Long Recording Time Allowing Rolling back to Points of Communications Failures

The LE-8200 has 100-MB capture memory that gains high-speed access to mega-speed communications, and is provided with ring and fixed buffer modes. The user can select the ring buffer mode for endless recording or the fixed buffer mode to stop recording automatically when the memory is full. Furthermore, the LE-8200 incorporates an auto save function that makes it possible to save the monitored content of captured memory on a high-capacity compact flash (CF) card in a specified file size continuously. This is useful for identifying rare communications failures of unknown causes.

[Continuous recording time reference *1]

| Applicable transmission speed | Main memory only | 32GB CF card *2 |
|-------------------------------|---------------------------|--------------------------|
| 9600bps | Approximately 6 hours | Approximately 1900 hours |
| 1Mbps | Approximately 220 seconds | Approximately 20 hours |

*1: In the case of full-duplex transmission of 1-kilobyte data at 1-millisecond intervals, both transmission and reception data will consume 4-byte memory for each capture.
*2: With the optional CF-32GX used.

Search Feature

The LE-8200 allows the scrolling or paging of measured data freely. This powerful feature makes it possible to search specific data items from a large volume of measured data and transmission or reception frames along with time stamps within a specified period, thus greatly increase the efficiency of offline analysis. The powerful search feature allows you to locate specific data and perform counting.

User Defined Translation Function

Users can translate designated data string in the frame to the specific characters or numbers. It is useful to analyze data of unique protocol format.

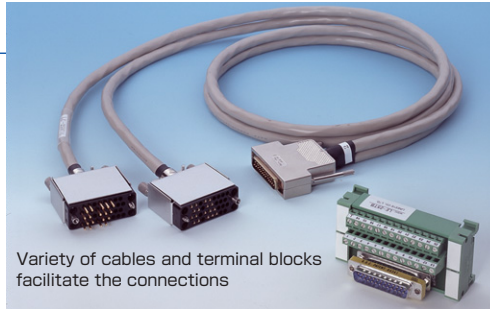

Variety of cables and terminal blocks facilitate the connections



Supporting Logic Analyzer Analysis and Analog Waveform Analysis New Function

The logic analyzer, which digitally displays the waveforms of communications line timing, operates at a sampling rate up to as high as 100 MHz. Furthermore, this feature realizes the simultaneous display of 12 lines by making use of the large-sized screen. Besides, the adoption of function keys ensures the operation of the time cursor with ease. Furthermore, if the OP-SB85L optional expansion kit is used, measurement of analog voltage waveforms at a maximum rate of 40M samples per second will be possible. Therefore, you will be able to realize detailed waveform observation without carrying a heavy general-purpose measuring instrument when you are on a business trip. These functions help to identify hardware problems. You can also use it for educational purposes, comparing documents for communications protocol.

[Example of Logic Analyzer Analysis]

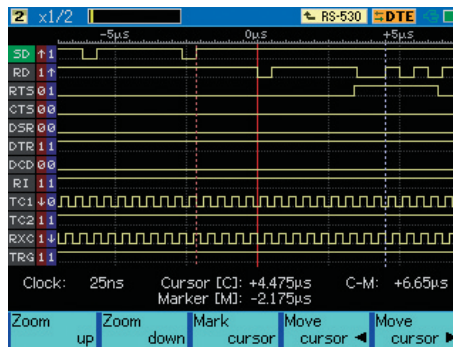

[Example of Analog Waveform Analysis]

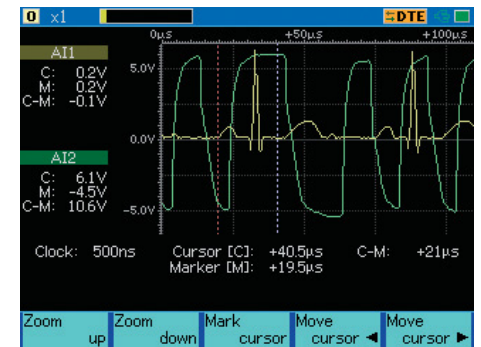

Trigger Function with Detection Capability Reinforced Twice Functional Enhancement

The trigger function controls the operation of measurement when the function detects specific communications status. Conventional models have four combinations of trigger conditions and trigger actions. On the other hand, the LE-8200 is provided with eight combinations for ease of making settings that are more flexible. This function not only enables the detection of eight types of conditions simultaneously but also makes it possible to detect particular conditions in sequence. Complicated communications events can be precisely grasped.

[Contents of trigger settings]

- Trigger 0: External trigger output in case of error generation.
- Trigger 1: Saves the data before and after idle time on the CF card when the idle time exceeds the set value.
- Trigger 2: Starts timer 0 when the specified signal line is 1.
- Trigger 3: Stops timer 0 when the specified signal line is 0.
- Trigger 4: Enables trigger 5 when start flags 01h, 02h, 03h, and F1h or 01h, 02h, 03h, and F3h are detected in sequence in SD.
- Trigger 5: Stops measurement immediately when 58h, 59h, 5Ah, arbitrary 2-byte data, and the end flag are detected in sequence in RD.
- Trigger 6: Stops measurement when timer 0 coincides with the set value.

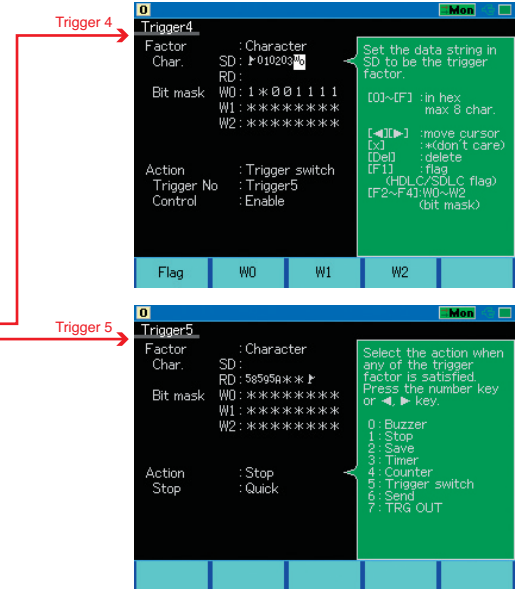
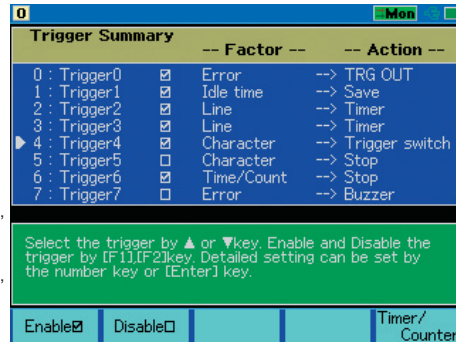

Voltage Measurement of Communications Line with Ease

With the feature of delay time measurement, a period of change of the communications control line from the present state to another can be measured at a 0.1-ms resolution. The feature is added with a function to measure the maximum, minimum, and present voltage amplitudes of SD, RD, DTR, and external EXT signals over RS-232C. This allows ease of the voltage amplitude measurement of wiring in connectors where the probes of testers cannot reach smoothly, thus contributing to the investigation of communications trouble caused by an insufficiency in the amplitudes of signals resulting from a circuit voltage drop.

[Example of analog & delay time measurement]

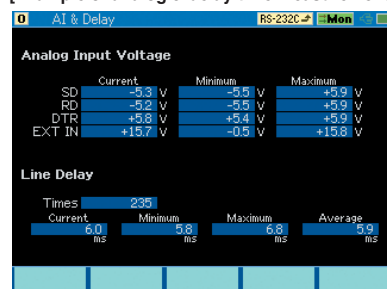

Graphic Display of Hourly Communications Status

This statistical analysis feature is used to measure the volume of communications and the number of occurrence times of specific communications status for a specified period ranging from 1 second to 240 minutes with the results graphically displayed. Condition 0 and condition 1 of the trigger function can be specified as target items. Therefore, it is possible to grasp not only the change of communications traffic (the rate of line usage) but also the number of transmission and reception times of specific data strings and the occurrence frequency tendency of errors on a time zone basis. Furthermore, the auto range display with increased graphic resolution allows ease of seeing slight changes.

[Example of graphical display of statistical analysis]

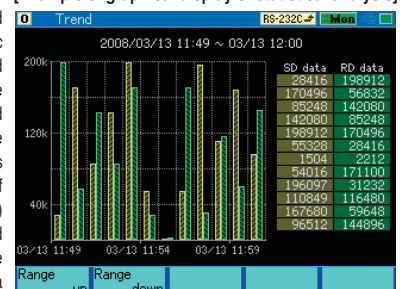

Simulation function provides the actual operating environments.

With the simulation feature, LINEEYE protocol analyzers act as the counterpart to the target device and perform transmission and reception tests according to protocol. Even in the early stages of development when matching devices are not available, it provides six types of simulation modes. Error handling process can be checked by sending data with parity errors. Margins can be evaluated by intentionally shifting communications speed. For example, test the 9600bps target device at 9840bps speed. In addition, data transmission can be linked with the changes in the signal lines, and an automatic control of RS-485 transmission driver IC is supported.

[Example of connection for simulation]

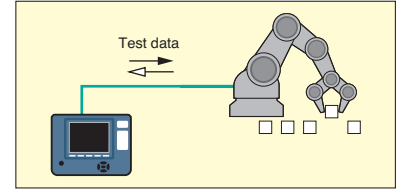

MANUAL mode

The MANUAL mode allows you to send the data registered in transmission table which corresponds to the "0" to "F" keys. The data can be sent with one press of a key. While checking replies from a unit under development with the monitoring feature, you can easily and simply test the communications process. You can also send fixed data by pressing a key combination of the SHIFT and "0" to "D" keys, as well as turn RTS/CTS and DTR/DCD signal lines on/off with the SHIFT and "E"/"F" key combinations.

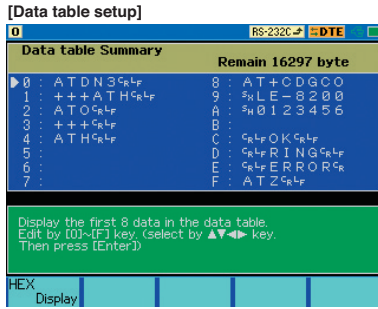

BUFFER mode

In the BUFFER mode, you can select between transmission and reception, and send transmitted or received data that has been captured in the buffer using the unit's monitoring capabilities, as simulation data without requiring further manipulation. This mode is effective in conducting reproducibility tests using the same data as that monitored under actual communications conditions.

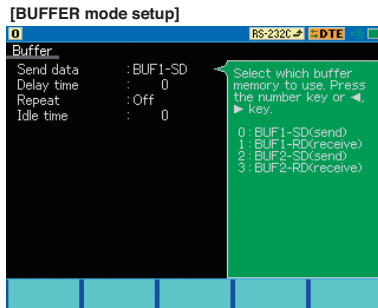

FLOW mode

Flow control can be simulated on the transmission and reception-lines using X-on/off flow control or the control line handshake. In the transmission mode, up to 16 cycles of data from transmission start until a generated interrupt request can be displayed. In the reception mode, you can set the number of received data cycles until a transmission interrupt request is generated, as well as the time until the transmission resume request is generated.

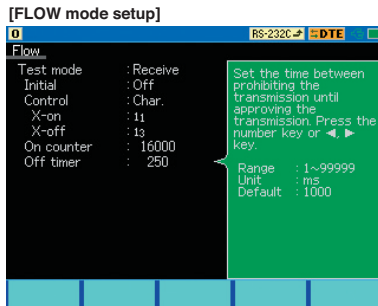

ECHO mode

In the ECHO mode, LINEEYE protocol analyzers internally return received data. Buffer echo to send back data by a frame, character echo to send back data by a character and loop back echo to return by the hardware can be selected. It is used to test display terminals and communications terminals.

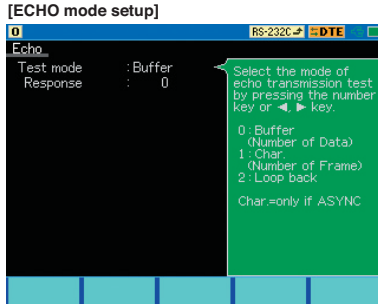

POLLING mode

The POLLING mode simulates the slave and master units in multidrop (1:N connection) polling protocols. In the slave mode, the LINE EYE protocol analyzers check the number of received frames that are assigned their address and whether errors occur or not, replying with user-set data. In the master mode, they send polling messages to 32 slave units, and check and display replies from each slave.

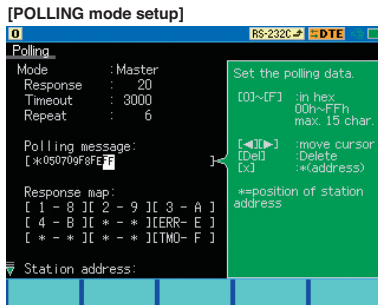

PROGRAM mode

By creating a purpose-specific command program, the communications protocol can be flexibly simulated alongside condition monitoring. The program is created using the menu selection, so it is easy to master.

[PROGRAM mode setup]

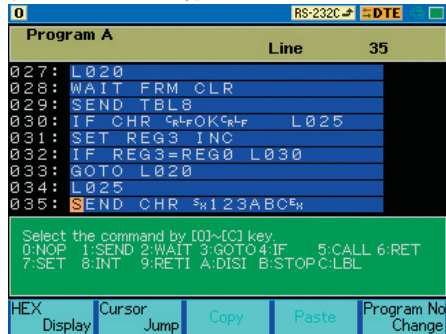

• Meaning

- 027: Label 020
- 028: Wait new receiving frame
- 029: Transmit data table 8
- 030: If receiving "CR, LF, O, K, CR, LF", jump to label 025
- 031: Set register 3 +1
- 032: If value of register 3 is equal to register 0, jump to label 030
- 033: Jump to label 020
- 034: Label 025
- 035: transmit "SX, 1, 2, 3, A, B, C, EX"

[PROGRAM mode commands table]

| Command | Operation |
|--|--|
| SEND CHR [] [] [] [] [] [] [] [] | Data transmission up to 8 characters. |
| SEND TBL [] | Data transmission of the specified data table. |
| SEND REG [] | Data transmission of the data table specified by a register value. |
| SEND BUF [] | Transmits data in the frame buffer. |
| SEND KEY [] | Transmits data in the transmission data table corresponding to keystroke. |
| SEND DA [] [] + REG [] | Transmits data of the data array specified by additional value of preset value of the data array number and the value specified by register number. |
| WAIT CHR [] [] [] [] [] [] [] [] | Waits for the particular character string of up to 8 characters to be received. |
| WAIT FRM CLR/NOCLR | Waits for a frame to be received. |
| WAIT TRG [] | Waits for a specified trigger condition to be specified. |
| WAIT TM [] [] [] [] | Waits for a specified period of time. |
| WAIT KEY [] | Waits until one of the keys from 0 to F is pressed. |
| WAIT LN [] = [] | Waits until the logical values of the control lines meet with the setting. |
| GOTO L [] [] [] [] | Jumps to a specified label number. |
| IF CHR [] [] [] [] [] [] [] [] L [] [] [] | Branches to a specified label number if the particular character string is included in the frame buffer. |
| IF TRG [] L [] [] [] [] | Branches to a specified label number if the trigger conditions are satisfied. |
| IF TM [] [] [] [] [] [] | Branches to a specified label number if the timer exceeds the setting value. |
| IF CT [] [] [] [] [] [] | Branches to a specified label number if the counter exceeds the setting value. |
| IF LN [] = [] L [] [] [] [] | Branches to a specified label number if the logic values of control lines meet with the setting. |
| IF REG [] [] REG [] [] [] [] | Branches to a specified label number if the inequality relation between registers is satisfied. |
| IF TBL [] L [] [] [] [] | Branches to a specified label number if it is satisfied with data of table specified by the table number. |
| IF DA [] [] + REG [] [] [] [] [] | Branches to a specified label number if data in the frame buffer is satisfied with data in the data array specified by the additional value, which is the sum of the designated value of a data array number, and the value designated in the register number. |
| CALL L [] [] [] [] | Jumps to a subroutine marked with a specified label number. |
| RET | Returns from the subroutine. |
| SET REG [] [] [] [] [] [] | Sets a value to register, or increments or decrements the register. |
| SET LN [] = [] | Sets a value of the control line. |
| SET TM [] [] [] [] [] [] | Sets a value to the timer, or controls the start, the stop or the restart of the program. |
| SET CT [] [] [] [] [] [] | Sets a value to the counter, or increments or resets the counter. |
| SET BZ | Sets the buzzer. |
| SET OUT | Outputs a pulse to the trigger out terminal. |
| SET DA [] [] [] [] [] [] [] [] | Sets data to the data array. |
| SET DV [] [] REG [] [] | Sets the specified number of characters on contents in register as a character string to the data array. |
| INT TRGO [] [] [] [] | Jumps to the subroutine marked by the specified label number when the condition of trigger 0 is satisfied. |
| RETI L [] [] [] [] | Returns from subroutine started by the INT command. |
| DISI TRGO | Disables an interruption. |
| STOP | Stops the running of simulation operation. |
| L [] [] [] [] | Enters a label number in a range from 0 to 999 in decimal notation. |

Measure transmission quality of communications lines by a loop-back or interactive connection.

BERT function enables you to evaluate parameters (bit error count, block error count) conforming to ITU-T G.821 Notification, hence enabling error rate evaluation and fault point identification. Elaborate test patterns and functions such as bit error forced interrupt are comparable to dedicated equipment.

[Example connection for BERT]

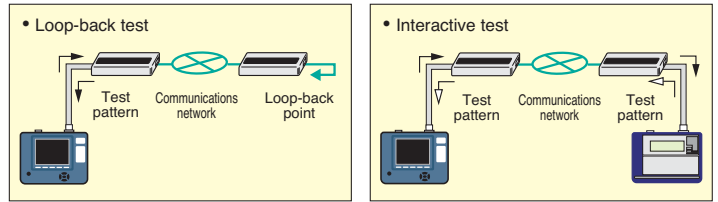

Many of test patterns

Evaluation is possible in ASYNC or SYNC mode, by specifying measurement period or test pattern. Three patterns are added for longer measurement period.

Graphs for specified measurement period

Records the results of more than one specified measurement period by using repeat mode. The movement of graph enables you to check the error rate easily.

[Example of BERT setting]

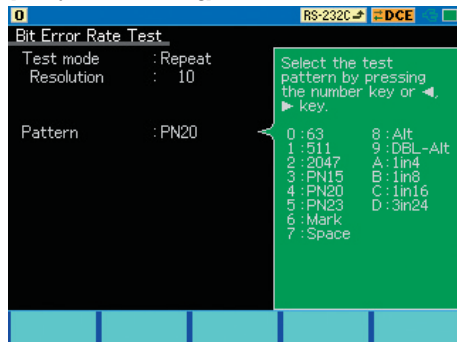

[Example of BERT measurement]

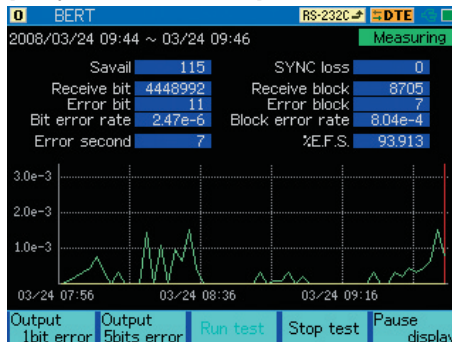

[Contents of BERT measurement]

| | | |
|------------------|----------------------------------|------------------|
| Savail | Available measurement in seconds | 0~9999999(sec) |
| Receive bit | Effective bits received | 0~9999999~9.99E9 |
| Error bit | Error bit count | 0~9999999~9.99E9 |
| Bit error rate | Bit error rate | 0.00E-0~9.99E-9 |
| Sync loss | SYNC loss count | 0~9999 |
| Receive block | Effective blocks received | 0~9999999~9.99E9 |
| Error block | Block error count | 0~9999999~9.99E9 |
| Block error rate | Block error rate | 0.00E-0~9.99E-9 |
| Error second | Error second | 0~9999999(sec) |
| %E.F.S | Normal operation rate | 0.000~100.000(%) |

Full of Convenient Functions for Efficient Measurement

Auto RUN / STOP Function

By making start and end time settings, automatic measurement will be possible for the specified period. This feature is useful for unmanned measurement with only an analyzer left on site.

The screen on the right-hand side is set to make measurement from 5:00 a.m. to 7:30 a.m. automatically on a daily basis.

[Example of auto RUN/STOP setting]

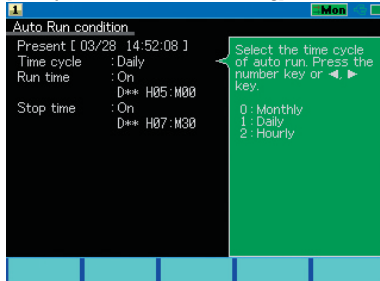

File Management Function

The file management feature makes it possible to save a number of test conditions and measurement data in the optional high-capacity CF card. This function supports file sorting and filtering, thus greatly improving file search performance. Moreover, the LE-8200 is safely designed. Therefore, if an automatic backup is set, measurement data will be saved automatically on completion of measurement.

[Example of file management]

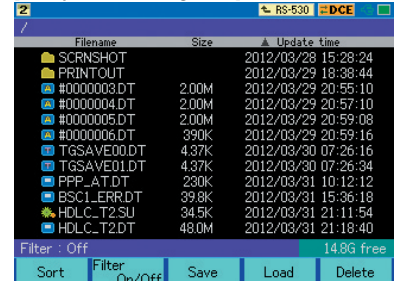

Monitor Condition Auto Setting

The communications conditions of lines, such as the communications speed and framing of the lines, can be automatically detected if relatively large volumes of communications data with few errors flows in the lines. This is effective for monitoring lines of unknown communications conditions.

* Accurate auto settings will not be possible for small volumes of communications data or data that contains many errors.

File Printout Function Functional Enhancement

The continuous printing of measurement data as well as the printing of screen display is possible in an appropriate format selected from a wide variety of formats according to the display mode of the screen. Printing images of text files and bitmap files can be saved on the CF card if the destination of output is specified as files, thus saving paper resources and making it possible to utilize data on personal computers at the same time.

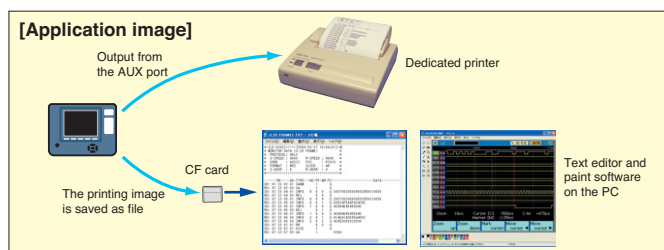

Firmware updating

The latest firmware with additional functions and improvements can be found on our website. Support to new communications standards and new functions with no interface change will be available by simply updating the firmware. When you download it to your PC, you can update the firmware over a serial cable or a USB cable.

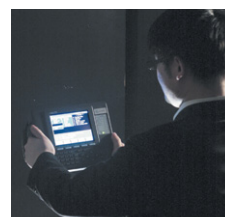
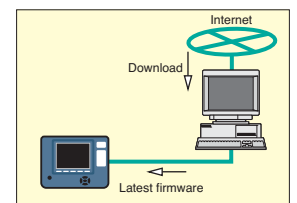

The LE-8200 incorporates a backlight, thus ensuring ease of operation in places with insufficient illumination.

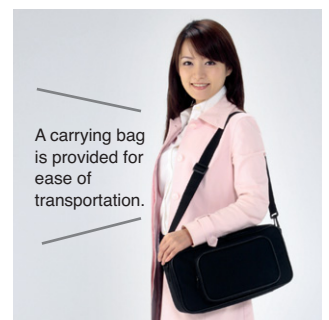

A carrying bag is provided for ease of transportation.

Additional data types can be measured by adding an interface expansion kit.



TTL I²C SPI TTL/I²C/SPI Communications Expansion Kit OP-SB85L

This interface expansion kit is equipped with a communication measurement port at TTL/C-MOS signal levels and a high-speed analog measurement port. This kit is ideal for observing/testing communication status by directly probing the communication line between the communication LSI and interface IC on printed circuit boards (PCB).



Support for a broad range of power supply systems.

This TTL/C-MOS measurement port can monitor signal levels of a broad range of power supply voltages. Of course, this port outputs a signal level ideal for the power supply system of the testing target during simulation.

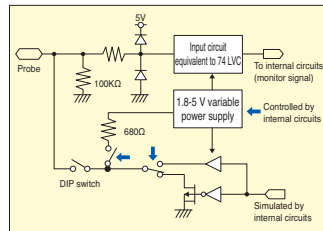

Monitor and simulate I²C/SPI

For I²C/SPI, this kit can not only monitor communication data but also simulate the master and slave stations. For I²C, 7 or 10-bit address is selectable. For SPI, the order of bit sending and a topological relation between the clock and data are selectable.

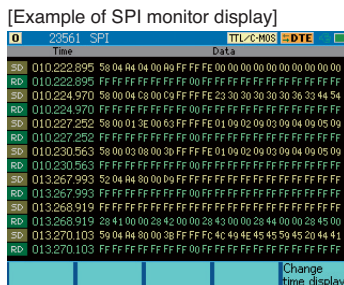
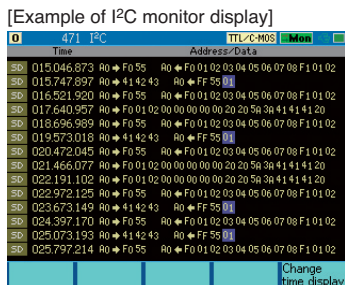
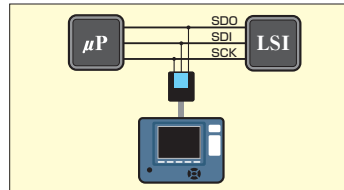
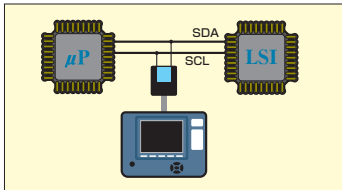

Ideal for UART ports or TTL-level HDLC

This kit is ideal for evaluation of microcomputer UART ports for ASYNC communications or communications modules which use TTL-level HDLC. It is also possible in the BURST mode to monitor such communications as cases when the clock is provided only when data are sent.

Waveform analysis function

The high-speed analog measurement port can measure waveform at a maximum speed of 40 M samples per second, which makes it possible to observe signal's rising waveforms. In addition, the communication measurement port with a test clip is usable as a logic analyzer with a maximum speed of 100 M samples per second, which is ideal for the measurement of delicate signal delay time.

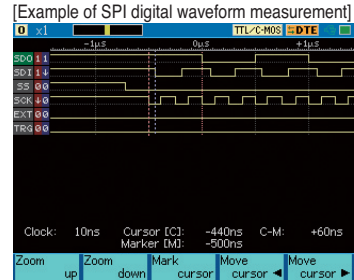
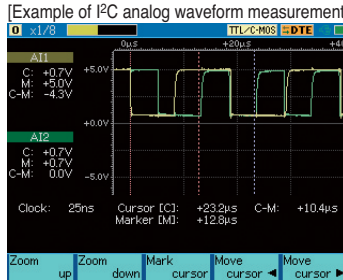

Specification

| | |
|---------------------------|---|
| Interface | TTL / CMOS (For I ² C, SPI) |
| Probe Signal | SD (SDA/SDO), RD (SDI), RTS (SS), CTS, EXIN, TXC (SCL/SCK), RXC, Trigger IN, Trigger OUT (Lead length: 170mm) |
| Protocol | ASYNC, ASYNC-PPP, SYNC/BSC, HDLC/SDLC/X.25, I ² C, SPI, Burst (*1) |
| Test Function | ASYNC, ASYNC-PPP, SYNC, BURST: 50bps~4Mbps (*2) HDLC : 50bps to 4Mbps (*2) on standard, 115.2Kbps to 12Mbps (*3) on using OP-FW12G SPI : 50bps to 2.15Mbps (*4), 115.2Kbps to 20Mbps (*5) on using OP-FW12G I ² C : max. 1Mbps (50K, 100K, 200K, 384K, 417K, 1Mbps for simulation) |
| Signal Level | Selectable from 5.0V/3.3V/2.5V/1.8V of power signal level |
| Input Impedance | 100KΩ (0V ≤ Vin ≤ 5V) (Acceptable input range: -1V to +7V) |
| Input Level Threshold | 5.0V setting; High: Min 3.5V, Low: Max 1.5V 3.3V setting; High: Min 2.0V, Low: Max 0.8V 2.5V setting; High: Min 1.7V, Low: Max 0.7V 1.8V setting; High: Min 1.2V, Low: Max 0.6V |
| Output Circuit | Select Open collector with the pull-up resistor of 680Ω, Open collector without pull-up resistor, or Push-pull output of CMOS. (*6) |
| Output Level Voltage | High: Min Selectable signal level - 0.4V, Low: Max 0.5V (*7) |
| Analog Measurement Port | Measurement channel: 2 Input impedance: 1MΩ (Acceptable input range: ±25V) Measurement range: ±6V / ±12V (8 bits resolution) Sampling cycle: 1ms - 25ns, 15 steps Record length: 4K point |
| Digital Waveform Analysis | Sampling cycle: 1ms - 10ns cycle, 16 steps |
| Composition | Dedicated expansion board, high-speed TTL probe pod, relay cable [length: 800mm], probe unit (LCU-01), 3-wire probe cable (LE-3LP2) |

*1: In BURST (Mode for capturing data at all clock SYNC), only the monitor mode is supported. I²C and SPI do not have the BERT function. *2: Applied in the half duplex. In the full duplex, 2.15Mbps at Max. *3: Applied in the half duplex. In the full duplex, 6Mbps at Max. *4: MAX 20Mbps (Monitor) or 4Mbps (Simulation), when the continuous transfer speed is less than 1K bytes. *5: Applied in the monitor mode. In the simulation mode, the speed is up to 12Mbps. *6: Set to the analyzer. Outputting CMOS is recommended on simulation of which speed is more than 2Mbps. *7: Applied when the current is 4mA.

Speed enhancement High-speed HDLC/SPI Communications Firmware OP-FW12G

This expansion firmware raises the speed of measurement tests for bit synchronous communications (such as HDLC/SDLC/X.25 or CC-Link) and SPI communications. This firmware processes main measurement items completely with a FPGA, thus precisely capturing communication data along with time stamps in 1-µs units.

HDLC and CC-Link

This firmware captures only the frames with a specified address (16 bits directly after the flag) to analyze them efficiently. For RS-485 half duplex communications, it is also possible to display the frames with a specified address on the SD side, and the other ones on the RD side to sort them so that they can be recognized easily.

SPI

This firmware can support all the four patterns of SPI transmission timing using a combination of clock polarities/phases. In addition, even if the SS signal is fixed to the low state, frames can be separated by setting up the pause time of the transmission clock on a 0.1 µs basis, so the relation between the transfer command and data can be analyzed efficiently.

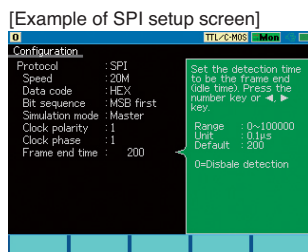
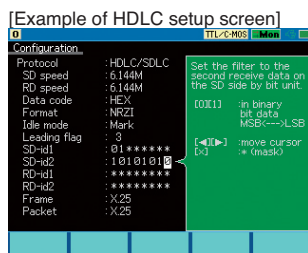

Specification

| | |
|---------------------|---|
| Interface | RS-422/485 (*1), TTL (*2), SPI (*2) |
| Protocol | HDLC/ SDLC/ X.25, CC-Link: NRZ/NRZI format, AR clock (*3) SPI: Clock polarity/ phase selectable |
| Baud Rate | HDLC, CC-Link: 115.2Kbps to full duplex 6Mbps/ half duplex 12Mbps (*4) SPI: 115.2Kbps to 20Mbps (*4) (*5) Speed is freely set to four effective digits |
| ID Filter (*6) | Specify address frame (16 bit length, don't care and bit masks available) |
| Error Check (*6) | FCS Error (CRC-ITU-T), Abort, short frame |
| SPI Frame Detection | SS rising, idle time of transferring clock (unit: 0.1us) |
| Time Stamp | 9 digits (0 to 134217727) Resolution: 1ms, 100µs, 10µs or 1µs |
| Trigger Function | Set 2 triggers (sequential setting available) up to 8 characters (don't care and bit masks available), communication error (HDLC only), external trigger input. |
| Simulation | Transmit pre-set data table (16 tables, total of 16K data) corresponding to the numerical keys. |
| Composition | Firmware CD, Instruction Manual |

*1: Use a RS-530 port. LE-25TB (DSUB25 pin terminal) is useful to connect to the target device. *2: Necessary to have OP-SB85/OP-SB85L. *3: The synchronous clock extracted from the transmission and reception data. *4: Necessary to have OP-SB85L for high-speed simulation of TTL/ SPI. *5: When transmission data continues more than 16byte, max speed may be at max. 6Mbps. For simulation, max 12Mbps (master mode)/ 6Mbps (slave mode). *6: HDLC/SDLC/X.25, CC-Link only.

IrDA ASK Expansion Kit for Infrared Communications OP-SB85IR

This expansion kit can measure/test IrDA (SIR/MIR/FIR) or ASK infrared communications. This kit is equipped with not only a monitoring function of infrared communication data but also a simulation function to send test data by infrared light emission, which is ideal for the development of portable apparatuses with infrared communications ports.

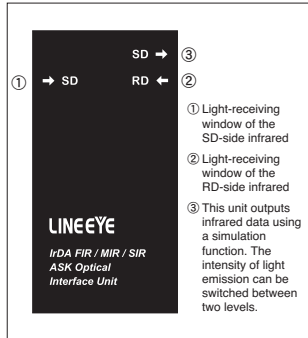
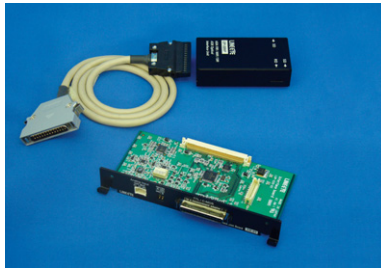

IrDA sent/received data are observed easily.

Setting is easily completed simply by placing an infrared measurement pod between the measurement target apparatuses.* Even if communication speed changes while IrDA data are sent between those apparatuses, this kit switches speed and frame format automatically by analyzing the IrLAP protocol, making it possible to measure data seamlessly.

* The probe pod for monitoring IrDA data is a patent technology of LINE EYE Co., Ltd.

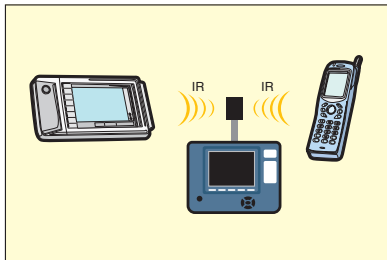

Data can be analyzed in detail on the translated display.

The data display screen can be switched to the translated display screen simply by pressing the [Data] key even during monitoring. This makes it possible to analyze the content of sent/received IrDA data frames.

[Example of IrDA raw data display]

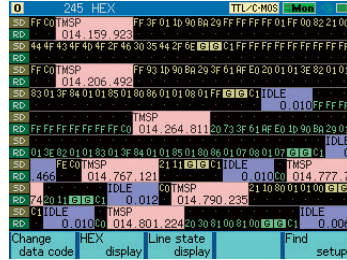

[Example of IrDA translated data display]

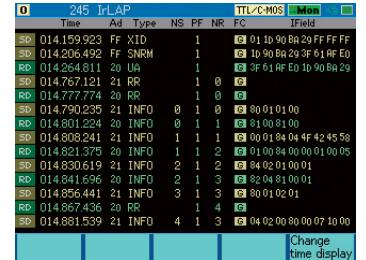

Specification

| | |
|---------------------------|--|
| Interface | Infrared rays, Photodiode: HSDL-3602 equivalent |
| Measurement Signal | SD, RD |
| Protocol | IrDA1.1 (SIR/MIR/FIR), ASK type |
| Test Function | Monitor / Simulation |
| Baud Rate (bps) | 2400, 9600, 19.2K, 38.4K, 57.6K, 115.2K, 576K, 1.152M, 4M |
| Automatic Speed Detection | Automatically detect target speed following IrLAP protocol. (*1) |
| SIR Frame Format | Asynch conformance (speed 2400bps - 115.2Kbps) [BOF]+[ADDR]+[control]+[information]+[FCS]+[EOF] It is possible to set not capturing after second BOF. |
| MIR Frame Format | HDLC conformance (speed 576Kbps, 1.152Mbps) [STA]+[STA]+[ADDR]+[control]+[information]+[FCS]+[STO] |
| FIR Frame Format | 4PPM encoding type (speed 4Mbps) [PA]+[STA]+[ADDR]+[control]+[information]+[FCS]+[STO] |
| Output Emission Level | High/Low interchangeable for simulation. |
| Analog Waveform Analysis | Measure signal voltages of 2 channels and display in analog waveform. (*2) Sampling: 1KHz to 40MHz (15 steps), 4K points Measurement range: ±6 V / ±12 V |
| Digital Waveform Analysis | Display emission level of infrared rays digital waveform. (Low: emission, High: light off) Sampling cycle: 1ms - 10ns cycle, 16steps |
| Composition | Dedicated expansion board, IrDA probe pod, relay cable [length: 800mm], 3-wire probe cable [LE-3LP2]. |

*1: Cannot have the automatic speed detection on IrSimple protocol. To measure only transferring data for IrSimple, set the speed to 4Mbps. *2: Peripheral circuit is measured and not IrDA emission signal itself. *3: Monitoring only. For simulation, transmission data signal toward IrDA photodiode is measured.

Current Loop Expansion Kit for Current Loop Communications OP-SB85C

This expansion kit supports the current loop communications, which is utilized in the FA field even now. For current loop communications, this kit realizes monitoring data, testing data sending/receiving, and measuring bit error rate.



Monitoring the current loop communications

Data are monitored by connecting this kit to the circuit monitored in series.

[Example of line connection for monitoring]

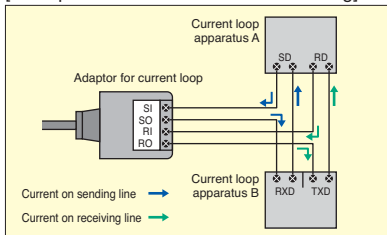

Testing data sending / receiving in the current loop communications

Data sending/receiving can be tested in passive and active manners.

[Internal circuit for simulation]

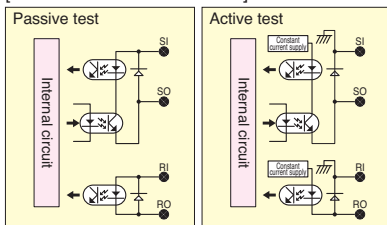

Measuring error rate in the current loop communications

By making data turn back on the side of the apparatus tested, error rate can be measured by comparing the sent and received data.

[Example of line connection for BERT]

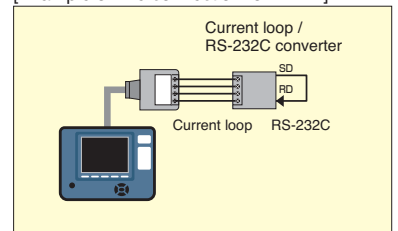

Specification

| | |
|--------------------------------|--|
| Interface | Current loop communications (4-pole terminal block, 7.62mm pitch/M3 screw) |
| Measurement signal | SD, RD |
| Baud rate | 19.2 Kbps max. (*1) |
| Test Function | Monitor, Simulation, BERT |
| Transmission Reception Circuit | Reception: Photodiode with a reverse connection protection diode. (*2) Transmission: Photo-transistor with a reverse connection protection diode. (*2) Acceptable max current: 70mA, Acceptable max voltage: 40V |
| Monitor current level | 10 to 60mA |
| Circuit type | Select passive type or active type. (*3) |
| Current Supply | Supply from inner power supply if active type is selected. Select 20 mA or 40mA. (*3) |
| Signal Polarity | Select normal (receive when carrying current) or invert (receive when not carrying current) (*4) |
| Analog waveform analysis | Signal voltages of 2 channels are measured and displayed in analog waveform Sampling: 1 KHz to 40MHz (15 steps) Measurement range: ±6 V / ±12 V |
| Digital Waveform Analysis | Display waveform of current status on Current loop. Sampling cycle: 1ms - 10ns sampling, 16 steps. |
| Composition | Dedicated expansion board, current loop adapter (OP-1C) (*5), relay cable [length: 800mm], 3-wire probe cable (LE-3LP2) |

*1: The baud rate is restricted by the cable length and current. *2: Current restriction resistor is not equipped. When using an external power supply, prepare a resistor not to exceed the max current capacity. *3: Select from the DIP switch on the current loop adapter. *4: Set in the analyzer. *5: OP-1C (Current Loop Adapter) is sold separately as well. OP-SB85L or OP-SB85IR combined with the OP-1C can be an equivalent set.

Stand-alone measurement of USB/LAN is realized easily by adding expansion kits.

USB Expansion Kit for USB 2.0 Communications OP-SB84

This interface expansion kit supports real-time monitoring of USB 2.0 protocol and power measurement of VBUS. Since USB 2.0 data can be measured easily without using a personal computer but using the analyzer only, this kit is ideal for the inspection and troubleshooting of installed apparatuses in addition to the development of USB apparatuses.

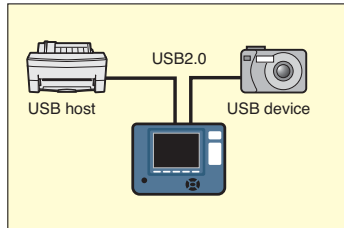
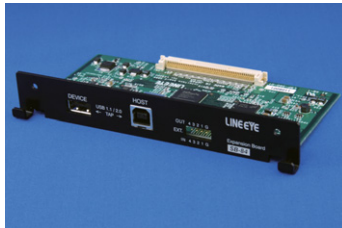

| LED | State |
|---------|---|
| High | High-speed mode |
| Full | Full-speed mode |
| Low | Low-speed mode |
| Data | Blinking: USB packets being received Not lighting: No USB packet |
| Suspend | Suspended |
| Reset | Reset |
| Vbus | Vbus |

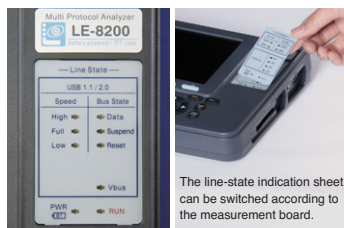

The line-state indication sheet can be switched according to the measurement board.

Powerful sequential trigger

This kit is equipped with a powerful triggering function which detects triggering conditions such as a communication error or occurrence of a particular transaction and stops issuing external signals and measurement automatically. Since up to eight conditions can be traced sequentially, data can be analyzed in an advanced manner by operating this kit together with an external instrument even in a complicated condition.

[Example of setup screen]

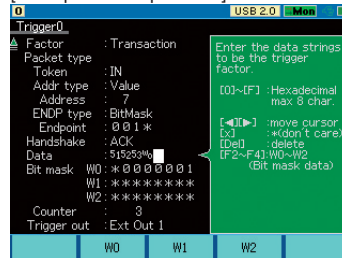

This setting means that the condition is fulfilled when a transaction configured with IN (with an address of 7 and an end-point of 3 or 2), DATA (with a payload of "51 52 53 01" or "51 52 53 81", and ACK packets has been detected in the third time. Then, a trigger mark is recorded, and the L-pulse is output to the external output terminal 1.

VBUS measurement function

This kit is equipped with a function to continuously measure the voltage, current, and power consumption of the VBUS line at up to 1 ms intervals as standard equipment. Data can be measured at any time easily because this kit is usable just by connecting the USB cable and troublesome probing is not necessary. It is also helpful for preparing a test report that measured data can be saved in a CSV file.

[Example of VBUS graph display]

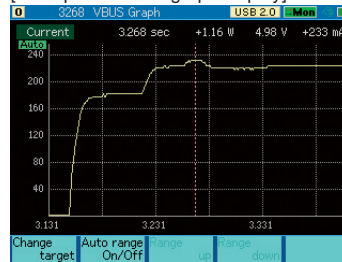

[Example of VBUS dump display]

| Time (Sec) | Power (mW) | Voltage (V) | Current (mA) |
|------------|------------|-------------|--------------|
| 3.149 | +0.02 | 5.10 | +3 |
| 3.150 | +0.02 | 5.09 | +3 |
| 3.151 | +0.13 | 4.98 | +26 |
| 3.152 | +0.29 | 5.02 | +57 |
| 3.153 | +0.35 | 5.02 | +72 |
| 3.154 | +0.42 | 5.02 | +84 |
| 3.155 | +0.50 | 5.02 | +99 |
| 3.156 | +0.56 | 5.01 | +111 |
| 3.157 | +0.59 | 5.01 | +118 |
| 3.158 | +0.65 | 5.01 | +130 |
| 3.159 | +0.69 | 5.00 | +137 |
| 3.160 | +0.75 | 5.00 | +149 |
| 3.161 | +0.78 | 5.00 | +155 |
| 3.162 | +0.80 | 5.01 | +160 |

Recording USB transmission in a large-capacity CF card

This kit judges the USB transmission speed of the device measured (1.5/12/480 Mbps) automatically, and displays the communication data and bus events of USB on the color LCD in a real-time manner as recording them in the 100 MB of capture memory incorporated in LE-8200 together with time stamps. In addition, this kit can record communication data in a large-capacity CF card continuously. Since there is a branch circuit with a high-impedance amplifier in the measurement section, the target USB line is not influenced.

[Example of basic display screen]

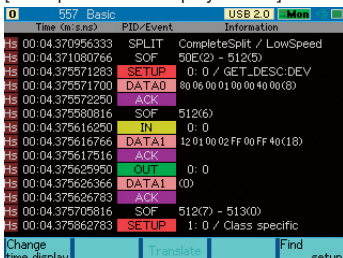

[Example of translated display screen]

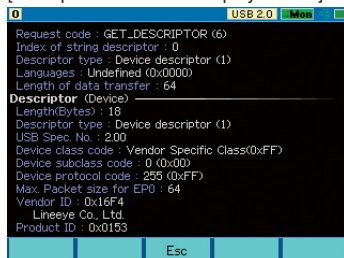

[Example of dump display screen]

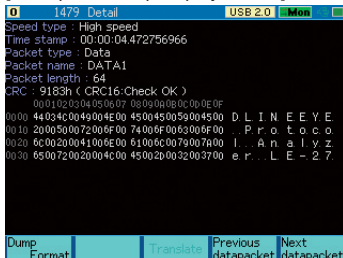

○ Measured data can be saved in a CF card as text, so that they can be utilized on a personal computer.

Data can be captured and displayed efficiently.

This kit is equipped with a log filter to capture efficiently the target USB packets only and a display filter to minimize analysis time.

[Example of setup screen]

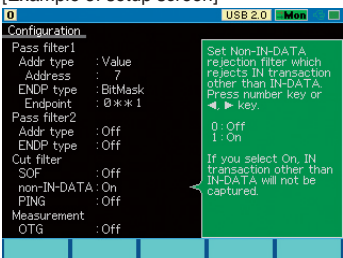

This is a setup example which captures only the transactions with a particular address (7) and a particular end-point (a binary number four digits long, and the first and fourth digit are 1 and 0, respectively) as eliminating the transactions such as IN-NAK, which is not necessary but occurs frequently. The "non-IN-DATA: On" setting in the "Cut filter" section means that IN transaction is not captured if no DATA packet comes after that IN transaction comes.

Specification

| | |
|-------------------------------|--|
| Interface | USB 1.1/2.0, USB standard A/B receptacle 1 each |
| Applied speed | HIGH (480Mbps) / FULL (12Mbps) / LOW (1.5Mbps) Automatic detection |
| Memory Capacity | 100MB |
| Record Type | Ring buffer or Full stop mode |
| Auto Save Function | Automatically save the USB log data in the CF card. ⁽¹⁾ |
| USB Log Display | Packet (SOF, IN, OUT, SETUP, DATA0, DATA1, ACK, NAK, STALL, PRE, DATA2, PING, MDATA, SPLIT, ERR, NYET, [Unknown]), Bus event (Reset, Suspend, Disconnect, Chirp, Vbus level), Translation (Standard device request, Standard device descriptor), HUB/HID class translation, Name of device request on Mass storage. ⁽²⁾ |
| Time Stamp | Resolution 16.7nsec for Max. 20 hours. Elapsed time and Time between two packets are selectable. |
| Log Filter | IN transactions without SOF/ IN-DATA, PING transactions, Vbus level. Record transaction of specific address/ endpoint. |
| Display Filter Function | Display or hide transaction of SOF, IN-NAK, OUT-NAK, SETUP, PING, specific address/ endpoint. |
| Trigger Function | Able to set 8 trigger conditions. Triggers are proceeded in a sequence from Trigger 0. |
| Trigger Condition | Errors (CRC and PID errors), Transaction (address/end points, Token and Handshake packets in combination, Payload of max 8 bytes from the head of DATA packets), Bus events, and the logical state of 4 external input pins. |
| Trigger Action | Output a signal from an external terminal after satisfaction of trigger condition. Stop measurement after satisfaction of the last trigger. Repeat the last trigger condition. Log continuously. |
| Retrieval Function | Retrieve the specified frame or event and display the top of data or count the number of data. |
| VBUS Measurement Function | Measure Vbus Current/ Voltage/ Power and display in Dump or Graph. Interval: 1ms - 1s (10 steps), Measuring times: 1 to 4194304 Voltage : 0 to +8V (Accuracy : ±1% FS) Current : -2 to +2A ⁽³⁾ (Accuracy : ±2% FS) |
| Data Conversion, Printout | Log data: Convert to text files, print out and save. ⁽⁴⁾ Vbus measured data: Convert to text/csv files, print out and save. |
| External Signal Input/ Output | TTL level input: 4, TTL level output: 4, Able to set work with trigger condition. |
| Composition | Interface expansion board, Line state sheet D, USB cable, Utility CD |

¹: On using ring buffer, measured USB data can be saved up to the capacity CF card. However, it is possible that there is some capturing loss for a large load data. ²: Translation of various class specific descriptors and device requests will be supported in the future. ³: "-" means the current direction from the device to host device. ⁴: It consumes much time to convert a large USB data into a text file on LE-8200. In this case, it is recommended to use "LEUCVT_WIN" which is much faster than LE-8200.

LAN Expansion Kit for LAN (PoE) Communications OP-SB89

This interface expansion kit supports the measurement test of Ethernet LAN. This kit is usable for not only analyzing communication data but also measuring the power of PoE (Power Over Ethernet) apparatuses or testing LAN cables. It is ideal for developing built-in apparatuses with LAN ports, evaluating communications, and maintaining/checking network cameras and wireless hubs compliant with the PoE specification.

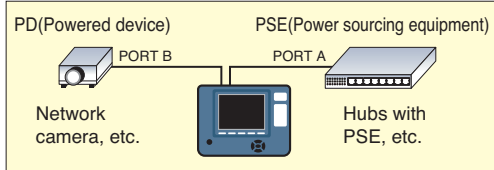
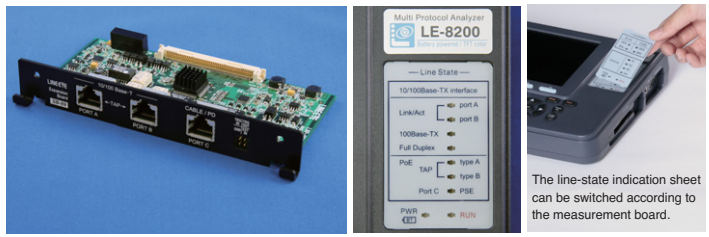

○ This kit can judge the PSE or type of the PoE.

Monitoring function

The measurement port is a fail-safe tap, so that the target line is not disconnected even if power supply to the analyzer is interrupted. Two monitoring modes are usable according to the test status:

| Monitoring mode | ONLINE mode | REPEAT mode |
|-----------------------|--|--|
| Measurement operation | Measurement stops automatically after saving 100MB in the buffer memory. | Measurement is performed continuously using two separated buffer memory alternately. |
| Real-time display | Impossible | Possible |
| Automatic saving | Impossible | Log files can be saved automatically for the capacity of a CF card. |
| Capturing performance | High | Slightly low because display processing and file processing increase. |
| Major application | Recording all frames on a high-traffic line | Continuous data recording for a long time on a relatively low-traffic line |

○ Data can be confirmed as switching the monitoring mode using a single-touch operation.

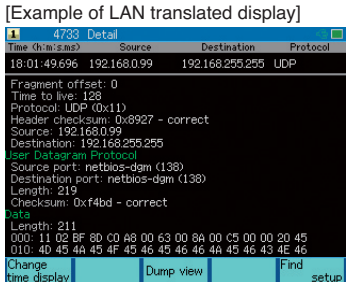
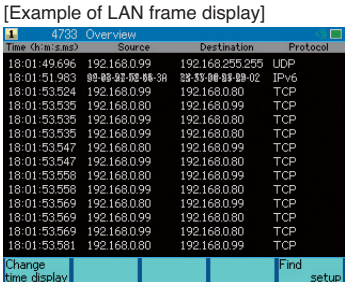

○ Log data can also be analyzed using free software such as Wireshark on a personal computer.

* Dedicated utility software is available, which converts a measured log file into a file of the Wireshark (.pcap) format.

Statistics analysis function

This kit can collect statistics of chronological change of communication traffic and the number of error packets.

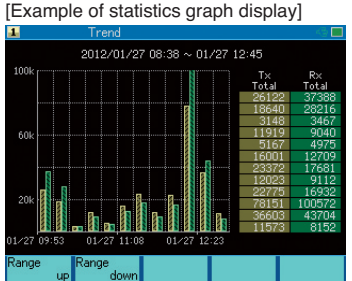
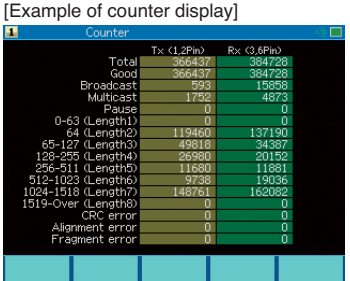

PoE measurement function

This kit can measure the voltage, current, and power consumption between the power sourcing equipment (PSE) and powered device (PD).

[Example of PoE measuring display]

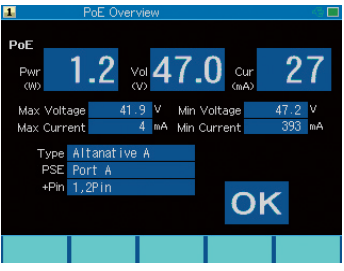

[Example of PoE graph display]

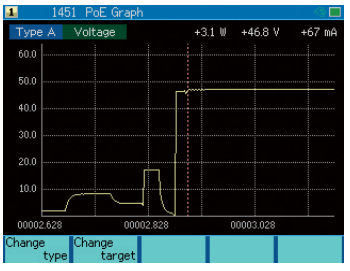

Useful functions on site

This kit is equipped with many functions useful on the site where LAN is installed: Pinging is helpful for the link confirmation test. Port blinking is a function which flashes the link lamps on the hub, which is useful for identifying multiple cables coming out of the floor. In addition, testing functions of LAN cables are available.

[Example of cable test display]

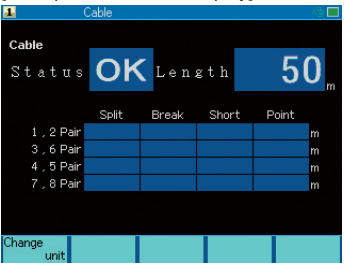

[Example of PING setup screen]

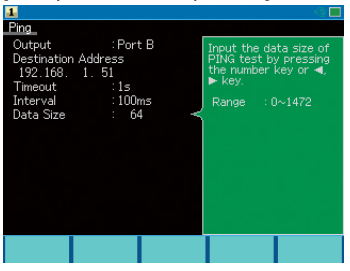

Specification

| | |
|-------------------------------|--|
| Interface | Port A,B: 10Base-T/ 100Base-TX (IEEE802.3) , PoE (IEEE 802.3af) Measurement Port C:Cable Test Port, Dummy PD port to detect PSE |
| Monitor Function | Measure/record LAN frames by TAP connection (*) of A/B ports. (**) |
| Memory Capacity | 100M byte, Max. 48,000-1,388,000 frames. (**) |
| Record Type | Memory full stop mode (ONLINE), and continuous recording mode (REPEAT) (**) |
| Auto save | Save LAN frames as log files into the CF card automatically (**) |
| Display Format | Frame/Translation/Dump (in HEX) Display. Translatable protocol:IPv4, ARP, ICMP, TCP, UDP, DHCP |
| Time stamp | Display unit selectable, Resolution: 1ms, 100μs, 10μs, 1μs selectable. |
| Log Filter | Type number, MAC address, protocol number, IP address, sub-net mask. |
| Retrieval Function | Retrieve the specific frame and display/count. Specify type number, MAC address, protocol number, port number, IP address, Sub-net Mask. |
| pcap file conversion | Provide a conversion software for Ethernet/ Wireshark (.pcap format). (**) |
| Statistic Function | Calculate the occurrence of LAN frames at the appointed conditions and display in graph. |
| PoE Measurement | Measure/record the PoE power consumption/ Voltage/ Current/ Power supply type, and OK/NG statement Interval (1ms-1s, 10 kinds), Measuring time : 1 - 4194304, Voltage: 0-60V, Accuracy : ±1% FS Current: 0-380mA, Accuracy : ±2% FS |
| Cable Test | Measure cable length/ short circuit/ split pair detection. (**) |
| PING Function | Transmit the PING commands to the PortA/B (**), and display response time and number of times. |
| Port Blink Function | LED for port A/B (*) connected to HUB will be blinking and easily find the target port. |
| PSE Detection | Light the LED when a PSE device is connected to PortC. |
| Print out/ Data conversion | Log data: Convert to text files, print out and save to CF card. PoE measurement data: Convert to text/ CSV files, print out and save to CF card. |
| External Signal Input/ Output | TTL level input: 1. Able to stop monitoring automatically when finding Low level. |
| Composition | Interface expansion board, line state sheet C, LAN cable, Utility CD |

*1 Port A/B has the fail-safe TAP and will not affect the communications between the target devices even when powering off the analyzer. *2: Recordable LAN frame size is 60 to 2047 byte. If the network consists of a large amount of traffic, it is possible that there will be some data loss. *3: Record 12byte of additional information per a frame. *4: Capturing capability of "REPEAT" mode is not good as the "ONLINE" mode. *5: For "REPEAT" mode only. Log file size is 50M byte fixed. *6: Utility software for Windows® 2000/XP/Vista/7 is stored in the CD. CF card reader slot are necessary in a PC. *7: It is the category 5e cable and margin of error is ±1m (3-20m)/±5% (20-120m). Set the cable calibration parameter to adjust the cable length. *8: When starting the cable test, Port A/B will become the LAN ports instead of TAP connection.

Large-capacity recording improves efficiency of the development of on-board networks and data analysis.

CAN

LIN

Expansion Kit for CAN/LIN Communications OP-SB87

This interface expansion kit can measure up to two channels of CAN/LIN communication data, which are broadly used in the FA field and in-vehicle communications, in a free combination. This kit can simultaneously measure external signals for four lines as digital or analog signals while measuring communication data.

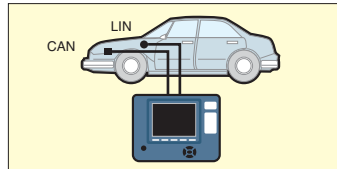
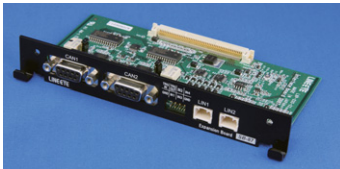

Monitoring functions

CAN
This kit supports CAN 2.0B, in which both the frames of 11-bit ID and 29-bit ID are used. Data can be evaluated flexibly using the free speed setting and the function for specifying bit capture timing.

[Example of CAN setup screen]



LIN
Data length and check-sum format can be specified for each ID of the target data. Measurement can be started quickly by specifying a frame end time even if data length is not clear.

[Example of LIN setup screen]

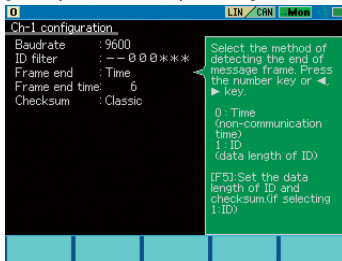

CAN and LIN communication data are monitored in a real-time manner. They can be analyzed by switching the display format using a single-touch operation.

External signals can be captured at specified intervals (1 ms to 10 min.) as well as recorded in synchronization with communication data.

[Example of external signal display]



[Example of chronological display]

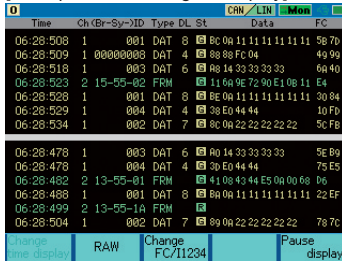

[Example of display by ID]

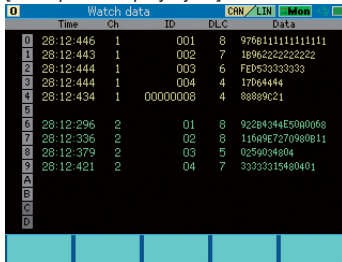

Simulation function

This kit can become a communication node of CAN / LIN to test sending / receiving data to the under-developed target apparatus.

CAN

This kit returns ACK automatically when a normal frame is received. Up to 16 types of test frames registered in advance can be sent at specified intervals using key operations. In addition, this kit can automatically change the data which is located in a specified position of the registered frames, so that the behavior of the under-development apparatus can be tested for the changed data.

[Example of CAN setup screen]

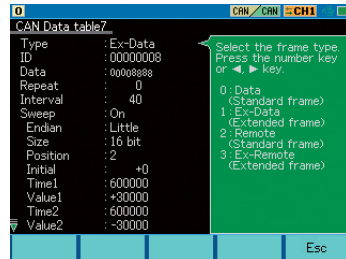

LIN

When simulating a master mode, up to 16 types of LIN frames registered in advance can be specified and sent in a free order for up to 16 steps. Since presence/absence of a parity error or an arbitrary BREAK length can be specified for each step, a flexible testing environment is realized including abnormal cases. When simulating a slave mode, a registered frame with the same ID is sent automatically in response to the request from the master.

[Example of LIN setup screen]

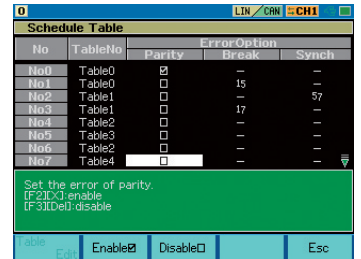

Specification

| | |
|---|--|
| Interface | CAN: Conforming to ISO11898/ISO15159-2 standards ⁽¹⁾ (DSUB 9-pin connector x 2) LIN: Conforming to ISO9141 (header 3-pin connector x 2) |
| Transceiver | CAN: TJA1050/1054 equivalent, LIN: TJA1021 equivalent |
| No. of channels | 2 channels of CAN/LIN, or 1 CAN and 1 LIN. |
| Expansion protocol | CAN2.0B, device network, LIN (Rev1.1, 1.2, 1.3, 2.0, 2.1) |
| Baud Rate (bps) | CAN: 1 Mbps max. LIN: 26 Kbps max. |
| Monitor function | CAN: Standard/Expansion format, bit timing arbitrary settings LIN: Set a frame end by idle time or ID setting. Arbitrary baud rate settings. |
| ID Filter | Record specific ID (bit mask is available). |
| Time stamp | Resolution: "Hr/Min/Sec", "Min/Sec/1ms", 100us, 10us, 1us (9 digits) |
| Trigger function | Specify the trigger conditions and actions (max. 8 kinds). Sequential action are available. |
| Trigger Condition | Error (Break, Sync, Parity, Framing, Checksum) ⁽²⁾ , specific data frame (Channel, ID, Payload), specific remote frame(channel, ID), timer and counter coincidence, external signal logic |
| Trigger Action | Measurement stop, saving in a memory card, timer/ counter control, specific data transmission, buzzer, validation of trigger conditions |
| Simulation function | Pre-registered data (max. 16 kinds) is transmitted by key operation. Increase/decrease data in the appointed position in a frame (sweep) ⁽³⁾ |
| CAN test | Transmit selected test frame for a specific number of times. |
| LIN test | Master mode: transmit test frame in the specific order. Slave mode: transmit when ID frame is matched. |
| Communication error test ⁽⁴⁾ | Parity error, Length of BREAK field (unspecified: 13bit), SYNC field value (unspecified: 55h) |
| External signal input | Real-time display of 4-channel external signal state with LED Record signal logic in synchronization with data Measure signal voltage continuously (Range: ±15 V, Accuracy: ±1%FS) |
| Composition | Dedicated expansion board, line state indication sheet B, DB9 monitor cable (LE-009M1) x2, 3-wire probe cable (LE-3LP) x2, 8-wire probe cable (LE-8EX) |

¹: It is selectable by changing the inner relay of analyzer setting. ²: It is available only by LIN except Checksum error. ³: It is possible to set an endian, initial and 3 types of desired value, and desired time. ⁴: It is available only by LIN.

FlexRay

Expansion Kit for FlexRay Communications OP-SB88

This interface expansion kit can simultaneously measure up to two channels of FlexRay communication data, which is used for a high-speed on-board network. Since communication data and analog signals of four points can be measured simultaneously, the relation between peripheral apparatuses and communication data can also be surveyed.

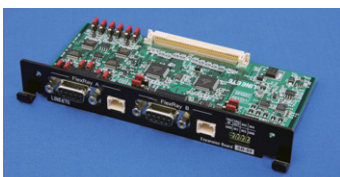

[Example of FlexRay monitor display]

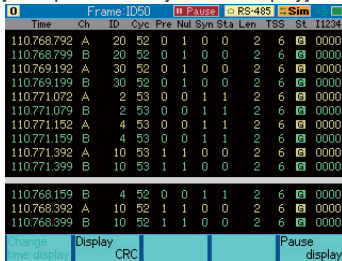

- Monitoring can be performed simply by setting a communication speed.
- One kit can simulate two FlexRay nodes.
- Data can be sent immediately because of the preset parameters.

<Paid support option>

This option is necessary for technical support regarding the usage of OP-SB88 and version upgrade. For details, contact our sales representative.

Specification

| | |
|-----------------------|--|
| Interface | FlexRay V2.1A, Connector: DSUB9pin x2, header 3pin x2 |
| Transceiver | TJA1080 or RS-485 ⁽¹⁾ 2 channels each |
| Baud Rate | 10Mbps, 5Mbps, 2.5Mbps |
| Monitor Function | Specific address frame. (16bit length, don't care and bitmask available) |
| Log Filter Condition | Received channel, each bit of indicator, ID, cycle counter |
| Display format | Frame, payload, specific frames (channel/ ID/ cycle counter) at the appointed position, event counter, external signal voltage |
| Trigger Function | Condition: 6 sets of appointed channel, indicator, ID, cycle counter, payload data (max. 16 data, don't care and bitmask available), error (Header CRC error/ Frame CRC error), external signal status Action: Measurement end, count, external signal output |
| Simulation Function | Transmit or receive data by two FlexRay nodes supported cold-start. ⁽²⁾ |
| Transmission Test | Test frame(0 to 254 bytes, Max. 784 kinds) repeatedly, event by key selection, start up frame/ Synch frame, preamble indicator available, wake-up/ media access test symbol |
| External Signal Input | Display 4 channels of status of external signals in LED at real time. Record signal status corresponding to data. Measure signal voltage continuously (range: ±15, accuracy: +3%FS) |
| Composition | Expansion board, firmware CD, Line state sheet(B), two DB9 monitor cable (LE-009M1) x2, Two 3-line-probe cable (LE-3LP) x2, 8-line-probe cable (LE-8EX) |

¹: RS-485 is equivalent to SN65HVD3088E. Select JFA1080 or RS-485 from analyzer. ²: Pre-set protocol of inner two nodes of analyzer and test board of Freescale for transmission and reception.

LE-PC800G Enhances the Link between Analyzers and your PC

PC Link Software

LE-PC800G

*Cannot be used with OP-SB87, OP-SB88, OP-SB89 and OP-SB84.

Enables simultaneous control of multiple analyzers from a PC

The LE-PC800G supports serial connections through the COM port, USB connections, and LAN connections via LINEEYE LAN-Serial converter, thus enabling remote measurement by multiple analyzers connected at the same time. It also allows you to browse measurement data saved in memory cards and convert data.

[Serial connections and memory card]

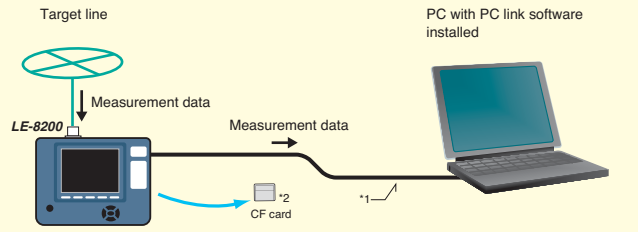

*1: The PC Link software is not provided with a use cable. Prepare a USB cable if you intend to use USB connection. The LE-82V AUX cable provided to the analyzer is available in the case of serial connection.
*2: An interface to read the CF card is required on the PC side.

[Linking multiple analyzers by serial and LAN connections]

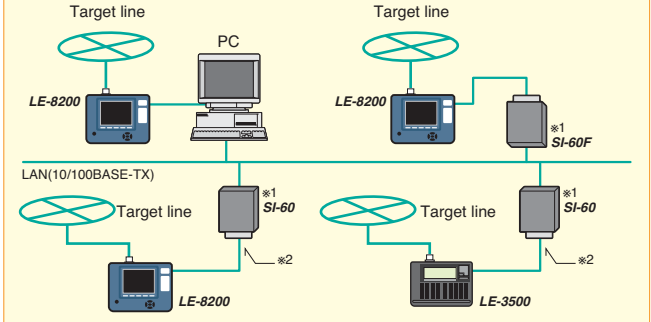

*1: SI-60/SI-60F is a LAN-serial converter supported by LE-PC800G. Target analyzer is identified by specifying IP address of SI-60/SI-60F on the remote setting window of LE-PC800G.
*2: Optional AUX cable for DSUB 25-pin (LE-8C). Set the DTE/DCE switch of SI-60 to DTE.

Allows the measurement data to be checked on your large PC screen.

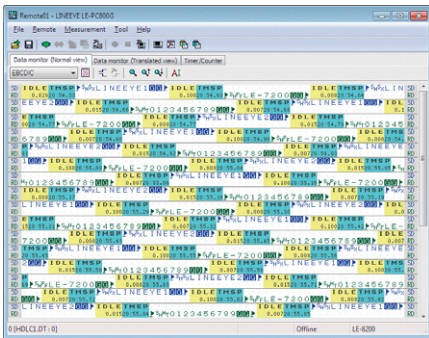

▲ Normal display

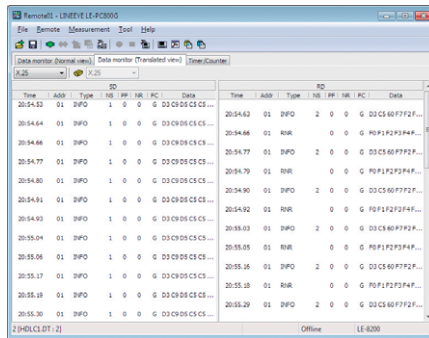

▲ HDLC translation display

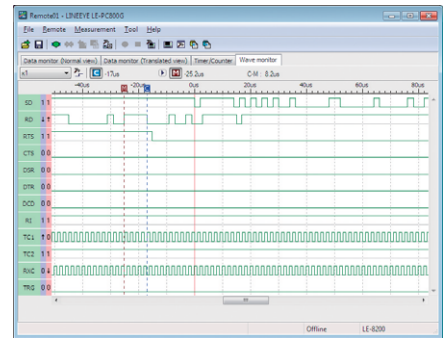

▲ Logic analyzer display

Records communication logs continuously on PC up to a maximum of 16GB

The remote monitor function allows to record the data measured by an analyzer on the hard disk of PC. The fixed buffer mode and ring buffer mode are available. The former stops recording when the specified data size is reached, and the latter records data endlessly within the limit of the specified size.

[Standard time for continuous recording on hard disk *1]

| Target line speed *2 | When 1 GB is specified : (e.g.: 1 MB x 1,000 files) | When 16 GB is specified : (e.g.: 8 MB x 2,000 files) |
|----------------------|--|---|
| 9600 bps | Approx. 60 hrs | Approx. 960 hrs |
| 19200 bps | Approx. 30 hrs | Approx. 480 hrs |
| 38400 bps | Approx. 15 hrs | Approx. 240 hrs |

*1: In case of full-duplex communications line for transmission at 1 ms interval per 1 KB.
*2: Maximum communications speed that ensures recording of measurement data without failure will be about 1/5 of serial transfer speed between analyzer and PC.

Converts the recorded data to text format or CSV format all at once

Multiple files of communications logs can be converted to text or CSV format for use on word processor or spreadsheet. Conversion to text is based on the print format of the analyzer. In consideration of analysis on general search tool, it is possible to delete decorative guides or time data, and to specify conversion of sender or receiver data only.

Changes the System Language Automatically

The system language alternates automatically between English and Japanese according to that of OS. This facilitates introduction of the software to development bases outside Japan.

Specifications

| | | | |
|-------------------------------|---|--|--|
| Analyzer connection | Serial, USB, and LAN (with SI-60/SI-60F unit sold separately) | | |
| No. of connectable analyzers | Multiple analyzers can be connected and controlled simultaneously.(No. of connectable analyzers depends on the performance of PC.) | | |
| Key emulation function | Presents the analyzer's display on the PC screen to enable control in a manner as if operating the analyzer. | | |
| Measurement condition setting | Measurement conditions (communications parameters, trigger and simulation data) can be input and edited on the PC. | | |
| Remote monitor function | Recording modes | Fixed buffer mode (Records data up to the specified size) or ring buffer mode (Records data endlessly while leaving the latest data of the specified size) can be selected. | |
| | Recording capacity | Max. 16 GB can be specified up to 2,000 files in the unit of 1/2/4/8 MB data file. | |
| | | Selectable among raw data, protocol translation and logic analyzer waveform. | |
| Display modes | Raw data | Displays communications data accompanied by idle time, time stamp and line status. Character code (10 kinds) and character size (small/medium/large) can be changed. | |
| | Protocol translation | Translates and displays SDLC, X.25 and LAPD protocols. (Target protocols planned to be increased.) | |
| | Logic analyzer | Enlarges and reduces waveform, measures time between cursors, and rearranges signals. | |
| Display area | Display window size can be changed. | | |
| Character codes | ASCII, EBCDIC, JIS7, JIS8, Baudot, Transcode, IPARS, EBCD, EBCDJK, HEX (in hexadecimal including error codes) Counts or displays the data that matches the search key. | | |
| Search function | Search key | Specified data string of max. 8 characters (don't care and bit mask available), idle time beyond a specified duration, specific time stamp (don't care available), error (parity, framing, BCC, break/abort, short frame) external trigger matching data | |
| Text-CSV conversion function | Specified number of recorded files can be converted to text or CSV format all together. | | |
| Bitmap conversion function | Analyzer's display shown by key emulation can be saved to bitmap files. | | |
| System requirements | PC | PC / AT compatible | CPU: Pentium3 1GHz or faster RAM: 512 MB or more (recommended) HDD: 5 MB + free bytes on the measurement data area |
| | O S | Windows® 2000/XP/Vista® /7 | |
| Composition | CD (Software) x 1, instruction manual x 1, user registration card x 1 | | |

PC Link Software for CAN/LIN

For OP-SB87 **LE-PC87**

This software links your PC and analyzer equipped with CAN/LIN communications expansion kit to analyze collected CAN/LIN data on your PC.

- USB, Serial and LAN connection to the PC
- Key emulation function for remote control
- Recode CAN/LIN data into the PC at maximum 16GB
- Display the specific ID frame at real time
- Data and timestamp search, text/CSV conversion
- Set the analyzer conditions from the software
- Read the measured file on the CF card
- OS: Windows® 2000/XP/Vista®/7

LE-8200 Specification

| | |
|--|--|
| Interface | RS-232C (V. 24), RS-422/485 (RS-530) |
| Expansion measurement interface ⁽¹⁾ | RS-422/485 terminal block [LE-25TB], X. 20/21 [LE-25Y15], RS-449 [LE-25Y37], V. 35 [LE-25M34], 1.8V/2.5V/3.3V/5.0V TTL/I ² C/SPI [OP-SB85L], Infrared communication IrDA/ASK [OP-SB85IR], Current loop [OP-SB85C], CAN/LIN [OP-SB87], FlexRay [OP-SB88], LAN (PoE supported) [OP-SB89], USB2.0 [OP-SB84] |
| Standard Protocol | ASYNC (Asynchronous), ASYNC-PPP, Character synchronous SYNC/BSC, Bit synchronous HDLC/SDLC/X. 25 |
| Optional Protocol | I ² C, SPI, BURST ⁽²⁾ , IrDA(IrLAP), CC-LINK, CAN, Devicenet, LIN, FlexRay, Ethernet, USB |
| Synchronous clock | ST1 (DTE transmission clock), ST2 (DCE transmission clock), RT (DCE reception clock), AR (The synchronous clock extracted from the edge of the transmission and reception data) |
| Capture memory ⁽³⁾ | Capacity : 100MB It is composed of DDR-SDRAM of which allows high-speed access . Two separated screens. Auto backup ⁽⁴⁾ . Error erasure prevention. Choose ring buffer or fixed size buffer. |
| Backup memory | Capacity:4MB It can be saved the measurement data and conditions by the built-in lithium battery for 10 years. |
| Max. speed | Full duplex: 2.150Mbps / Half duplex: 4.000Mbps |
| Speed setting range | 50bps to 4.000Mbps Freely set to four effective digits, separately for transmission and reception. (Margin of error: ± 0. 01% or less) |
| Expansion speed (HDLC mode) | 115.2Kbps to 12Mbps [OP-FW12G] |
| Data format | NRZ, NRZI, FM0, FM1, 4PPM, ASK, Manchester 0, Manchester 1 |
| Data code | ASCII, EBCDIC, JIS7, JIS8, Baudot, Transcode, IPARS, EBCD, EBCDIK, HEX |
| Character Framing | ASYNC : data bit (5, 6, 7, 8) + parity bit (0, 1) + stop bit (1, 2) Character synchronous : data bit + parity bit (6 or 8bits in total) Bit synchronous : data bit (8bits) |
| Parity bit | NONE, ODD, EVEN, MARK, SPACE |
| Multiprocessor bit | MP (multiprocessor) bit is shown with a special mark. |
| Bit transmission order | LSB first or MSB first (switchable) |
| Polarity inversion | Normal, Invert (switchable) |
| Error check | Parity (ODD, EVEN, MARK, SPACE), Framing, Break, Abort, Short frame, BCC (LRC, CRC-6, CRC-12, CRC-16, CRC-ITU-T, FCS-16, FCS-32). BCC permeation mode. |
| Online monitor function | Communication log is recorded continuously and displayed in the LCD without affecting the communication lines. |
| Idle time display | OFF (no record); Resolution: 100ms, 10ms, 1ms; Max 999. 9 sec |
| Time stamp display | OFF (no record); Date time stamp: unit selectable among "Yr/Mon/Day/Hr/Min", "Mon/Day/Hr/Min/Sec" and "Day/Hr/Min/Sec/10ms"; Elapsed time from the measurement start: Resolution 100μsec/10μsec/1μsec (9digits) |
| Line status display | Records and displays the wave form of 7 signals (chosen from RS(RTS), CS(CTS), ER(DTR), DR(DSR), CD(DCD), CI(RI), TRGIN(external trigger input) along with the transmission/ reception data. |
| Address filter | Records only frames of the specified address. (only when HDLC/SDLC/X.25) |
| Data display and operations | Pause in capture, two seperated screens, scroll, paging, jump to the specified screen. |
| Bit shift display / Line Break | Entire frame can be shifted to the right or left in 1 bit increments. ASYNC frames can be displayed in the new line by each time stamp. |
| Protocol translation display | SDLC (modulo 8/128), ITU-T X.25 (modulo 8/128), LAPD, PPP, BSC, IrLAP, I ² C, User defined |
| Line status LED | Two color LEDs of SD, RD, RS(RTS), CS(CTS), ER(DTR), DR(DSR), CD(DCD), CI(RI), ST1(TXC1), ST2(TXC2), RT(RXC). |
| RS-232C | Logic ON (red) , logic OFF (green) , no connection NC (light off) |
| Other I/F | Logic ON (red) , logic OFF or no connection NC (light off) |
| Interval timer | 4kinds; Max. count: 999999 (Resolution: 1ms ,10ms ,100ms) |
| General-purpose counter | 4kinds; Max. count: 999999 |
| Data counter | For SD and RD (1 each): Max. count: 4294967295 |
| Trigger function | Up to 8 pairs of trigger condition and action can be specified. (sequential action, which validates another condition after one condition satisfied, is also possible.) |
| Trigger condition | Communication error (Parity, MP, framing, BCC, break, abort, short frame can be specified individually.), communication data string up to 8 characters (don't care and bit mask available), idle time more than the specified duration, match time/counter value, logic status of interface signal line and external trigger input |
| Trigger action | Stops measurement/test (offset can be set), validates trigger condition: controls timer (start/stop/restart), controls counter (count/clear), activates buzzer, saves monitor data on a memory card, sends the specified character string (during manual simulation), sends pulse to external signal |
| Data search function | Retrieves the data with specific condition from capture memory. |
| Search condition | Communication error (Parity, MP, framing, BCC, break, abort, short frame),communication data string up to 8 characters (don't care and bit mask available), idle time more than the specified duration, specified timestamp (don't care available), trigger matching data. |
| Search action | Shows the match data at the top or enumeration display (selectable) |
| Monitor conditions auto setting | Measurement conditions such as protocol, transmission speed, (max. 115.2Kbps), data code, synchronous character and BCC check can be set. |
| Auto run/stop function | Enables measurement to start and end at the specified time at the selected repeating cycle (monthly, daily, hourly). |
| Auto save function | Automatically saves the monitored data in the capture memory and saves as communications log file in the CF card. |
| File size | BUF (capture memory size) , 1MB , 2MB , 4MB , 8MB, 16MB , 32MB , 64MB |
| Max files | 1024 |
| Delay time function | Measures and displays the interval of change in the interface signal line. (current/min/max/average, resolution: 0. 1ms) |
| Signal voltage measuring function | Measures and displays the value of voltage amplitude: SD, RD, ER(DTR), external signal EXIN. (current/min/max, range± 15V resolution : 0.1V) |
| Statistical analysis function | Takes statistics and displays graphs of transmission/reception data count, number of frames, and satisfied trigger condition count. Range:1 sec - 240min |
| Logic analyzer function | Measures the logical change of the interface signal in the sampling clock period, and displays its wave. |
| Sampling clock | 1KHz to 100MHz (16 steps) |
| Sampling memory | Min 4,000 |
| Trigger condition | Trigger conditions in the ONLINE monitor functions match. Logical status match between interface signal line and external signal. |
| Trigger position | Before, center, after |
| Zoom in/out | x10, x5, x2, x1, x1/2, x1/4, x1/8, x1/16, x1/32, x1/64 |
| Other functions | Time measurement by cursor, signal line exchange, signal status search |

| | |
|--|---|
| Bit error rate test | At DTE or DCE mode (It is possible to change the pin arrangement), line quality measurement test such as error rates can be done by loop back test or interactive test. |
| Communication mode | Synchronous (SYNC), Asynchronous (ASYNC) |
| Measuring speed | 50bps~4.000Mbps, freely set to four effective digits |
| Measurement mode | Continuous measurement, specifies the number of receiving bit, specifies the time to measure, repeatedly measurement at the unit of 1 - 1440 min. |
| Test pattern | 2 ⁶ -1, 2 ⁹ -1, 2 ¹¹ -1, 2 ¹⁵ -1, 2 ²⁰ -1, 2 ²³ -1, MARK, SPACE, ALT, DBL-ALT, 3in24, 1in16, 1in8, 1in4 |
| Error bit insertion / notification | Inserts 1-bit or 5-bit error in test pattern by key operation. Outputs a pulse to the external trigger terminal when finding an error bit. |
| Measurement range | It is able to measure the parameter of the ITU-T advice G.821. Effective received bit (0 to 99999999 to 9.99E9), bit errors (0 to 99999999 to 9.99E9), bit error rate(0 to 9.99E-9 to 1), block errors (0 to 99999999 to 9.99E9), block error rate (0 to 9.99E-9 to 1), Savail(available measurement time: 0 to 9999999sec), loss count (synch loss: 0 to 9999), error duration (0 to 9999999sec), %EFS (normal operation rate: 0.000 to 100.000%) |
| Simulation function | Enables transmission/reception test of any given data in DTE or DCE mode (selectable with pin assignment). |
| Transmit data entry | Can be registered in 16 types of transmission data tables (Total of 16 K data). |
| Error data entry | A part of transmission data can be registered as error data such as parity error. |
| Line control mode | Auto (Controls transmission timing with RS(RTS), CS(CTS), ER(DTR), CD(DCD) signal lines automatically in 1 ms increments) or manual (key operation) can be selected. |
| Transmit driver control | Auto control (Turns ON driver only before and after data transmission) or manual mode (link with ER(DTR), CD(DCD) key operation) can be selected during simulation of RS-485. |
| MANUAL mode (Manual test) | Sends the data assigned to operation keys each time a key is pressed, while checking communications status on the display. Can be used together with the trigger function. |
| FLOW mode (Flow control test) | Simulates the X-on /X-off control data and flow control procedures of RTS/CTS control line. (Sender and receiver selectable) |
| ECHO mode (Echo test) | Sends the received data frame by frame (buffer echo), by data (character echo) or by loop back. |
| POLLING mode (Multi-polling test) | Simulates multi-polling communications procedures. (Sender and receiver selectable) |
| BUFFER mode (Buffer transmission test) | Reproduces transmission of selected data (SD or RD) captured in memory by monitor function. |
| PROGRAM mode (Program simulation) | Creates a simulation program (Max. type: 4, Max steps: 512) using the dedicated commands (36 types) to test the communication procedure. |
| File management function | Measurement data and condition can be saved in the CF card. And the format of the data/condition can be used in the PC. |
| File types | Measurement data (.DT), measurement condition (.SU), trigger save data (TG SAVEnn.DT), auto save data (#nnnnnnn.DT), auto back-up data(@AUTOBU0/1/2.DT) |
| File controls | Normal file display, sort display, file display by specified type, save, load, delete, delete all, format |
| Memory card | 2G byte to 32G byte CF card (only the LINEEYE guarantees to use). |
| Printout function | Measurement data can be printed in various formats. Text files can be saved in the CF card. Screen image can be printed and saved in the CF card. |
| LCD | 5.7 inch TFT color liquid crystal display. 320 x 240 dot. LED back light can be adjusted. |
| AUX(RS-232C) port | Mini DIN8 pin connector. Communication speed: 9600bps to 230.4Kbps (6 steps) Print out data, Can be used with PC [PC link software], Can be used to upgrade the firmware. |
| USB2.0 port | B-connector in device side. Transfer data in high-speed. Can be used with PC [PC link software], Can be used to upgrade the firmware. |
| Power supply | Built-in nickel hydrogen battery or AC adapter DC9V, 2A(AC100 to 240V, 50/60Hz). |
| Battery operating time (*5) | About 4 hours Power saving mode: Auto back light off, Auto power off (It will not work while measuring.) |
| Battery charging time | About 2.5 hours |
| Ambient temperatures | In operation : 0 to 40 degrees, In storage : -10 to 50 degrees |
| Ambient humidity | In operation : 20~80%RH (No condensation), In storage : 10~85%RH (No condensation) |
| Standard | CE(class A), EMC(EN61326-1 : 2006) |
| Dimension (*6), mass | 240 (W) x 190 (D) x 48 (H) mm , about 1.1Kg |

*1 : To have the function, optional accessory described in "[]" is needed. *2 : Mode in which all data is imported in synch with clock edge.
 *3 : Only 1M of capture memory will be backed up by the battery. Transmission/reception data, idle time, time stamp, line status consume 4 bytes of memory at each capture.
 *4 : This function automatically saves the measurement data in the CF card or back up memory, when the measurement end. *5 : Under the normal operation.
 *6 : Hand strap is not contained.













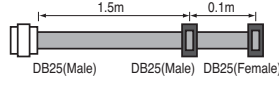

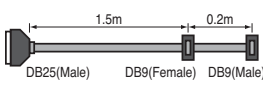
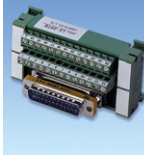
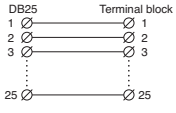

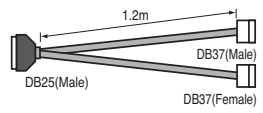

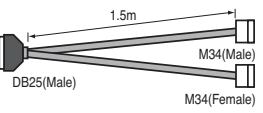
Standard Set

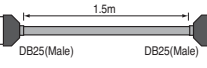
- Portable communication analyzer..... 1
- DSUB 25-pin monitor cable (LE-25M1)..... 1
- DSUB 9-pin AUX cable (LE2-8V)..... 1
- External signal input/output cable (LE-4TG)..... 1
- Hand strap..... 1
- Line state sheet..... 1
- AC adapter (3A-183WP09)..... 1
- Carrying bag (LEB-01)..... 1
- Utility CD..... 1
- Instruction manual..... 1
- Warranty..... 1

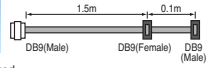
*Hand strap is already set in the analyzer.

Options for LE-8200

• Cables / terminal blocks / Converter

| | | | |
|--|---|--|---|
|  <p>Monitor cable for DSUB 25-pin LE-25M1 Branch cable for monitoring communication lines over general DSUB 25-pin.</p>  <p>1.5m 0.1m DB25(Male) DB25(Male) DB25(Female)</p> <p>*Same as the cable packed with analyzer.</p> |  <p>Monitor cable for DSUB 9-pin LE-259M1 Branch cable for measuring RS-232C over DSUB 9-pin of PC, etc.</p>  <p>1.5m 0.2m DB25(Male) DB9(Female) DB9(Male)</p> |  <p>Terminal block for DSUB 25-pin LE-25TB Converts analyzer's RS-485/422 port (DSUB 25-pin specification) to terminal block specification.</p>  <p>DB25 Terminal block 1 1 2 2 3 3 ... 25 25</p> | |
|  <p>X.21 Monitor cable LE-25Y15 Branch cable for measuring X.20/21 over DSUB 15-pin. (Shield type)</p>  <p>1.2m DB25(Male) DB15(Male) DB15(Female)</p> |  <p>RS-449 Monitor cable LE-25Y37 Branch cable for measuring RS-449 over DSUB 37-pin. (Shield type)</p>  <p>1.2m DB25(Male) DB37(Male) DB37(Female)</p> |  <p>V.35 Monitor cable LE-25M34 Branch cable for measuring V.35 over M34-pin.</p>  <p>1.5m DB25(Male) M34(Male) M34(Female)</p> | |
|  <p>RS-530 cable LE-25S530 Shield cable for RS-530 interface.</p>  <p>1.5m DB25(Male) DB25(Male)</p> |  <p>DB9 monitor cable LE-009M1 Monitor cable for measuring CAN and Flexray over DSUB 9-pin.</p>  <p>1.5m 0.1m DB9(Male) DB9(Female) DB9(Male)</p> <p>*Same as the cable packed with OP-SB88/OP-SB87.</p> |  <p>3 Line probe cable LE-3LP Probe cable for measuring LIN and FlexRay signal.</p> <p>*Same as the cable packed with OP-SB88/OP-SB87.</p> |  <p>External signal cable LE-4TG Probe cable for inputting/ outputting external signal.</p> <p>*Same as the cable packed with analyzer.</p> |
|  <p>AUX cable for DSUB 9-pin LE2-8V Cable for connection AUX (RS-232C) port of an analyzer with PC (DSUB 9-pin DTE specification). • Length: 2.5m *Same as the cable packed with analyzer.</p> |  <p>AUX cable for DPU-414 LE2-8P Cable for connection AUX (RS-232C) port of analyzer and serial port of DPU-414 (printer). • Length: 1.5m</p> |  <p>LAN-RS232C converter SI-60F Converter for connecting an analyzer and a PC via LAN.</p> | <h3>• Carrying bag</h3>  <p>Carrying bag LEB-01 Bag with pockets for storing and carrying accessories such as AC adapter, cables, etc. *Same as the carrying bag packed with analyzer.</p> |

• Memory card

| | |
|--|--|
|  <p>32G byte CF card CF-32GX 32G byte compact flash card. *It is verified by the analyzer. *The photo is for illustrative purpose only</p> |  <p>16G byte CF card CF-16GX 16G byte compact flash card. *It is verified by the analyzer. *The photo is for illustrative purpose only</p> |
|--|--|

• AC Adapter



Wide input AC adapter 3A-183WP09
Input: AC100-240V, 50/60Hz
Output: DC9V, 2A
Plug: center⊕

*Same as the carrying bag packed with analyzer.

• Battery pack



NIMH battery pack for replacement P-20S
• Rating: 6V, 2100mAh

*Battery pack for replacement.

Compact thermal Printer

Compact thermal printer DPU-414-41B-E
Built-in battery, dedicated roll paper (x1) included.
*AC adapter and cable are not prepared. Provide them separately.

Compact Thermal Printer Set DPU-414-PA
Includes printer (DPU-414-41B-E), roll paper x1, AC adapter, and printer cable (LE2-8P).

Handy thermal printer for on-site printout of measurements

- Prints 40 digits per line in normal mode and 80 digits in reduced mode.
- High-speed printing at 52.5 characters per second.
- Incorporates eco-friendly NiMH battery.
- Supports Centronics parallel and RS-232C ports.
- Dimensions: 160(W)x 170(D)x 67(H)mm
- Weight: Approx. 690g (including built-in NiMH battery)



Options
AC adapter for DPU-414
Output: DC7.0V, 2.5A(center⊖)
PW-C0725-W1-U
Input: AC100V~240V
Roll paper TP-411L
TP-411L
Thermal roll paper for DPU-414.
10 rolls per carton.
Width: 112mm Length per roll: Approx. 28m

Battery pack for DPU-414
BP-4005-E
Same as NiMH battery built-in DPU-414-41B-E.
4.8V, 1100mAh

MULTI PROTOCOL ANALYZER **LE-3500**

Sister Product



Standard model of multi protocol analyzer has mega speed measurement, wide memory capacity and program simulation functions.

| | |
|-------------------|--|
| Baud Rate | Full duplex 1.544 Mbps Half duplex 2.048 Mbps |
| Memory | 6.4 Mbyte |
| Display | Monochrome with back light |
| Battery Operation | 8 Hours |
| Dimensions | 210(w)x154(D)x38(H)mm |
| Weight | Approx. 790g |



SAFETY WARNING
Read the instruction manual provided with the product before use and use the product as explained in that manual. Using the product in ways not guaranteed in the manual, connecting it to systems outside of the specified ranges and remodeling can all cause trouble and damage. LINEEYE CO. LTD. will assume no responsibility whatsoever for trouble or damage arising because of unauthorized ways of use.

- All brand names and product names mentioned in this catalog are trademarks or registered trademarks of their respective companies.
 - Specifications and designs of products listed in this catalog are as of April 2012, and are subject to change without notice for improvement.
 - Colors of actual products may differ slightly from that listed due to printing condition.
 - This catalog may not be reprinted or duplicated, in part or in whole.
- ©2012 by LINEEYE CO., LTD.

LINEEYE CO., LTD.

■ Head Office/Sales Office
Marufuku Bldg 5F, 39-1 Karahashi Nishihiragaki-cho, Minami-ku, Kyoto, 601-8468
PHONE: 81-75-693-0161 FAX: 81-75-693-0163

● URL <http://www.lineeye.com>

● E-mail : info@lineeye.co.jp

* LINEEYE CO. LTD. is a venture company founded by electronic equipment development members of the former Sekisui Chemical Co., Ltd. with investment from the Sekisui Venture Fund. The electronic equipment business of Sekisui Electronic Co. Ltd. was transferred to LINEEYE CO. LTD. in October 2000.



Printed in Japan

L-12402E/LE©